

maxema®

BUY LESS PR

S PENS.



BUY LESS

PUSH-BUTTON / TAPPINO



C



MATT



CR



GOLD



M1



M2



M3



M4

BARREL / FUSTO



C



30

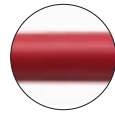

MATT

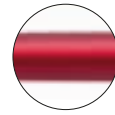

FROST

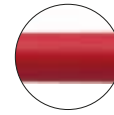

GOM



AL

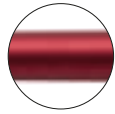

MET

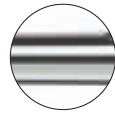

M1

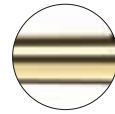

M2

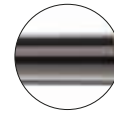

M4

CLIP

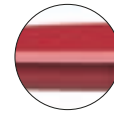

C

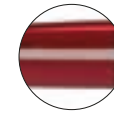

30

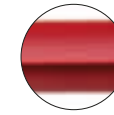

MATT



AL



MET

CAP / CAPPUCCIO



C

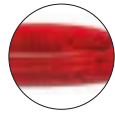

30



MATT

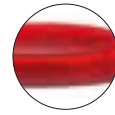

FROST

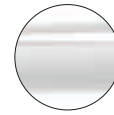

TEXTURE

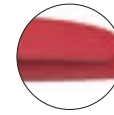

GOM

TIP / PUNTA



C



30



MATT



FROST



AL



CR



GOLD



M1



M2



M3



M4

PLUG / TASSELLO



C



AL



CR

RINGS / ANELLI



C



CR



GOLD

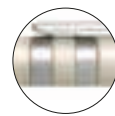

AL



Made
in Italy



Prodotto
in Italia



Fabriqué
en Italie





Fabricado
en Italia

Contents Indice

Maxema, just a pen? 07
Maxema, solo una penna?

Maxema recycled world 08
—

Icon Pure – Recycled  NEW 12
twist-action / meccanismo a rotazione
IC8 – MATT RE 14



Flow Pure – Recycled  NEW 16
twist-action / meccanismo a rotazione
F2P – MATT CB RE 18
F2P – MATT RE 20









Dot – Recycled  NEW 22
retractable / meccanismo a scatto
D1 – MATT CB RE 24
D1 – MATT RE 26

Zink – Recycled  NEW 28
twist-action / meccanismo a rotazione
Z1 – CB RE 30
Z1 – C RE 32



Pixel – Recycled  NEW 34
retractable / meccanismo a scatto
PX40 – MATT CB RE 36
PX40 – MATT RE 38

Bay – Recycled  NEW 40
twist-action / meccanismo a rotazione
B500 – MATT RE 42

Mood Metal   46
retractable / meccanismo a scatto
MD1 – M M1   48
MD1 – M M4   50
MD1 – M M2   52

Mood 54
retractable / meccanismo a scatto
MD1 – C M1   56
MD1 – GOM CB M1   58
MD1 – GOM C M1   60
MD1 – GOM 30 M1   62

MD1 – C M2   64
MD1 – C M3   65

Icon Pure  66
twist-action / meccanismo a rotazione
IC8 – GOM  68

Flow Pure 70
twist-action / meccanismo a rotazione
F2P – GOM MATT  72
F2P – MATT CB 74
F2P – MATT 76
F2P – MATT F 78
F2P – C 80
F2P – GOM K 82
F2P – GOM CB 84
F2P – GOM 30 86
F2P – GOM CF 88
F2P – GOM KF 89
F2P – GOM 30 F 90

Flow 92
twist-action / meccanismo a rotazione
F1 – MATT AL 94
F1 – C CR 96
F1T – GOM C CR 98
F1T – GOM CB CR 100
F1T – GOM 30 CR 102

Dot 104
retractable / meccanismo a scatto
D1 – MATT B 106
D1 – MATT CB 108
D1 – MATT 110
D1 – MATT K 112
D1 – MATT F 114
D1 – B CR 116
D1 – CB CR 118
D1 – C CR 120
D1 – 30 CR 122
D1 – GOM K 124
D1 – GOM CB CR 126
D1 – GOM C CR 128
D1 – GOM 30 CR 130
D1 – C GOLD 132
D1 – GOM KF CR 133

Zink 134
twist-action / meccanismo a rotazione
Z1 – CB 136
Z1 – C 138
Z1 – 30 140
Z1 – CF 142

View 144
twist-action / meccanismo a rotazione
V1 – C CR / V1 – C CR T 146
V1 – 30 CR / V1 – 30 CR T 148
V1 – AL CR / V1 – AL CR T 149
V1 – GOM C CR / 150
V1 – GOM C CR T

Tag 152
twist-action / meccanismo a rotazione
TA1 – MATT AL B 154
TA1 – B CR 156
TA1 – C CR 158
TA1 – MET AL 160
TA1 – AL CR 161

Icon 162
twist-action / meccanismo a rotazione
IC400 – MATT 164
IC400 – FROST 165
IC400 – MATT AL 166
IC400 – C CR 168
IC400 – FROST AL 170
IC400 – 30 CR 171
IC400 – C GOLD 172
IC400 – MET AL 173
IC400 – AL CR 173

Tag green 174
twist-action / meccanismo a rotazione
TA2 – B 178
TA2 – BC 179

Icon green 180
twist-action / meccanismo a rotazione
IG2 – BC 184
IG2 – C 185

Ethic 186
twist-action / meccanismo a rotazione
ET900 – MULTICOLOUR 188
ET900 – FLAG 189
ET900 – C FLAG 189
ET900 – B 190
ET900 – BC 191
ET900 – C CR 192
ET900 – C GOLD 193
ET900 – AL 194
ET900 – AL CR 195
ET900 – AL FLAG 195
ET900 – MET CR 196
ET900 – MET AL 197

Next 198
retractable / meccanismo a scatto
NX400 – C CR 200
NX400 – 30 CR 201

Pixel 202
retractable / meccanismo a scatto
PX40 – MATT CB 204
PX40 – MATT CR 206
PX40 – B 208
PX40 – C 209
PX40 – 30 210
PX40 – FROST NEUTRAL 211
PX40 – FROST 212
PX40 – GOM C CR 214
PX40 – GOM 30 CR 215

Bay 216
twist-action / meccanismo a rotazione
B500 – MATT BC 218
B500 – MATT 220
B500 – BC 222
B500 – C 223
B500 – 30 224
B500 – FROST 225

Technical information 227
informazioni tecniche

Packaging 246

Sales support 250
supporti di vendita

Inks and refills 256
inchiostri e refill

inside front flap / interno aletta di copertina

Finishes
finiture

inside back flap / interno aletta retro di copertina

Colour palette
palette colori

Maxema, just a pen?

EN

Would you ever have thought that it takes more than a year to make a pen? A year during which we look for the right lines, the safest plastic and the colours that best represent each brand. Because a promotional pen must not only be of top quality; it must also write well and communicate effectively.

Our pens are designed and produced in our sole Italian headquarters, where we are able to control every step in the process, from the first prototypes to the final product.

We look after every detail, starting from the selection of raw materials: the plastic, refills and internal springs come only from Italian or German suppliers who can guarantee their full quality and reliability. Only in this way can we make the image of each brand unique and recognisable.

IT

Avresti mai detto che per costruire una penna ci vuole più di un anno di lavoro? Un anno in cui cerchiamo le linee giuste, la plastica più sicura e i colori che rappresentano al meglio ogni brand. Perché una penna promozionale, oltre a essere di qualità e a scrivere bene, deve anche comunicare in modo efficace.

La progettazione e la produzione delle nostre penne avviene nella nostra unica sede italiana, dove possiamo controllare ogni passaggio, dai primi prototipi al prodotto finale. Curiamo tutti i dettagli, a partire dalla selezione delle materie prime: plastica, refill e molle interne provengono solo da fornitori italiani o tedeschi in grado di garantirne la piena qualità e affidabilità. Solo così possiamo rendere l'immagine di ogni brand unica e riconoscibile.

Scegli un prodotto che dura nel tempo.

CHOOSE BETTER. MAKE IT LAST.

EN

Who said good things don't last? At Maxema, we do everything we can to make our pens live for as long as possible. A Maxema pen loves nature: the longer it lasts, the less it pollutes. And, since one life seemed too short for us, we have created a new line in recycled plastic, beautiful to look at and even more environmentally friendly. All our pens can be made of recycled plastic: choose your favourite model, inspired by the colours of Nature.

IT

Chi l'ha detto che le cose belle durano poco? Noi di Maxema ce la mettiamo tutta per far vivere le nostre penne il più a lungo possibile. Una penna Maxema ama la natura: più tempo dura, meno inquina. E, visto che una vita sola ci sembrava troppo breve, abbiamo realizzato una nuova linea in plastica riciclata, bella da vedere e ancora più attenta all'ambiente. Tutte le nostre penne possono essere realizzate in plastica riciclata: scegli il tuo modello preferito, ispirato ai colori della natura.



Una vita sola non basta.

ONE LIFE IS TOO SHORT.

EN

Why use plastic only once when it can be turned into something new?

For our recycled plastic pens we use materials of European origin that are 100% derived from post-consumer products. When appropriately treated, these guarantee high quality plastics, certified and compliant with RoHS and REACH regulations.

IT









Perché usare la plastica una volta sola quando può trasformarsi in qualcosa di nuovo?

Per le nostre penne in plastica riciclata usiamo materiali di origine europea derivanti al 100% da prodotti post-consumo che, opportunamente trattati, garantiscono materie plastiche di elevata qualità, certificate e conformi alle normative RoHS e REACH.

La Terra è piena di sfumature.

THE EARTH IS FULL OF COLOURS.

solid / coprenti

06		ICE	10		CLOUD
76		DESERT	87		MUD
19		FOREST	21		ABYSS
58		GRAPHITE	07		ONYX

Icon Pure

△ RECYCLED

The purity of simplicity.
La purezza della semplicità.

All-round personality.
Personalità a tutto tondo.

NEW

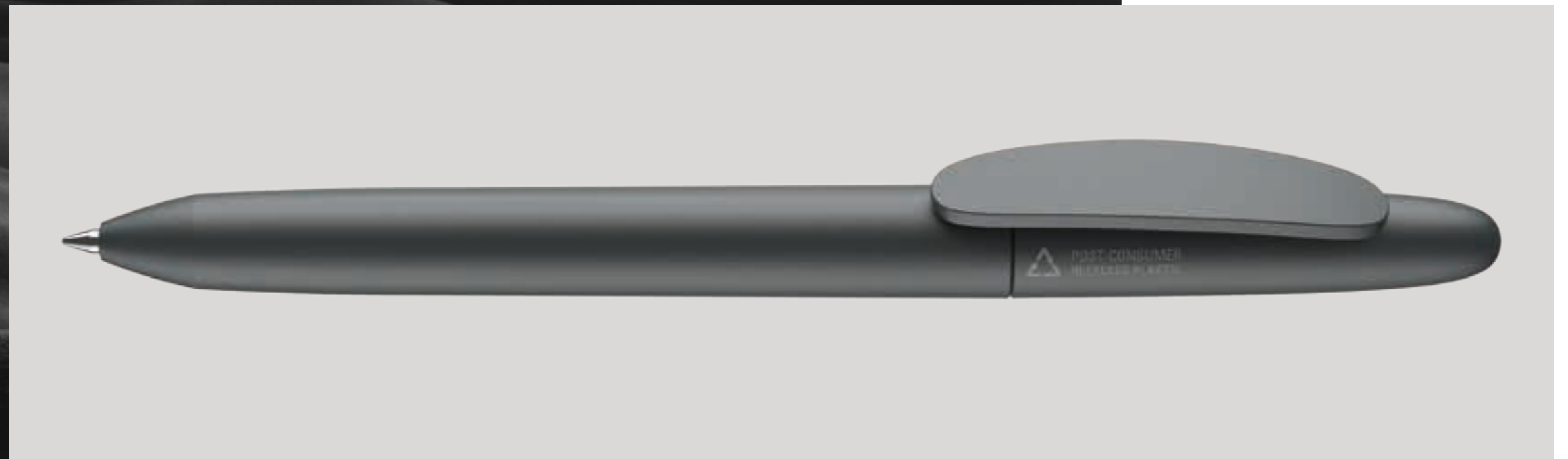

QUALITY NOT QUANTITY

The entire Maxema collection is available in recycled plastic on request /
Tutta la collezione Maxema è realizzabile in plastica riciclata su richiesta

Technical information at p. 230
Informazioni tecniche a pag. 230

Recycled plastic
Solid colours with matt finish

Design embraces
sustainability.

NEW



06

10

76

87 mud / pad printing 35 x 7 mm
tampografia 35 x 7 mm



Plastica riciclata
Colori coprenti con finitura satinata

Il design abbraccia
la sostenibilità.



19

21

58

07 onyx / pad printing 35 x 7 mm
tampografia 35 x 7 mm



MY BOX RECYCLED

Universal reclosable single pen box
in recycled Fedrigoni paper.
Info at p. 248

*Astuccio universale richiudibile per penna
singola in cartoncino riciclato Fedrigoni.
Info pag. 248*

Flow Pure

△ RECYCLED

Free from extra.
Pura ed essenziale.

The essence of design.
L'essenza del design.

NEW



QUALITY NOT QUANTITY

The entire Maxema collection is available in recycled plastic on request /
Tutta la collezione Maxema è realizzabile in plastica riciclata su richiesta

Technical information at p. 231
Informazioni tecniche a pag. 231

Recycled plastic
Solid colour barrel and cap, solid white
colour clip, matt finish

NEW



10



76



87 mud / pad printing 40 x 9 mm
tampografia 40 x 9 mm



19



21



58



07 onyx / pad printing 40 x 9 mm
tampografia 40 x 9 mm

Plastica riciclata
Fusto e cappuccio in colore coprente,
clip in colore bianco coprente,
finitura satinata



MY BOX RECYCLED

Universal reclosable single pen box
in recycled Fedrigoni paper.
Info at p. 248

*Astuccio universale richiudibile per penna
singola in cartoncino riciclato Fedrigoni.
Info pag. 248*

Recycled plastic
Solid colours with matt finish

For responsible
consumption:
more quality, less
quantity.

NEW

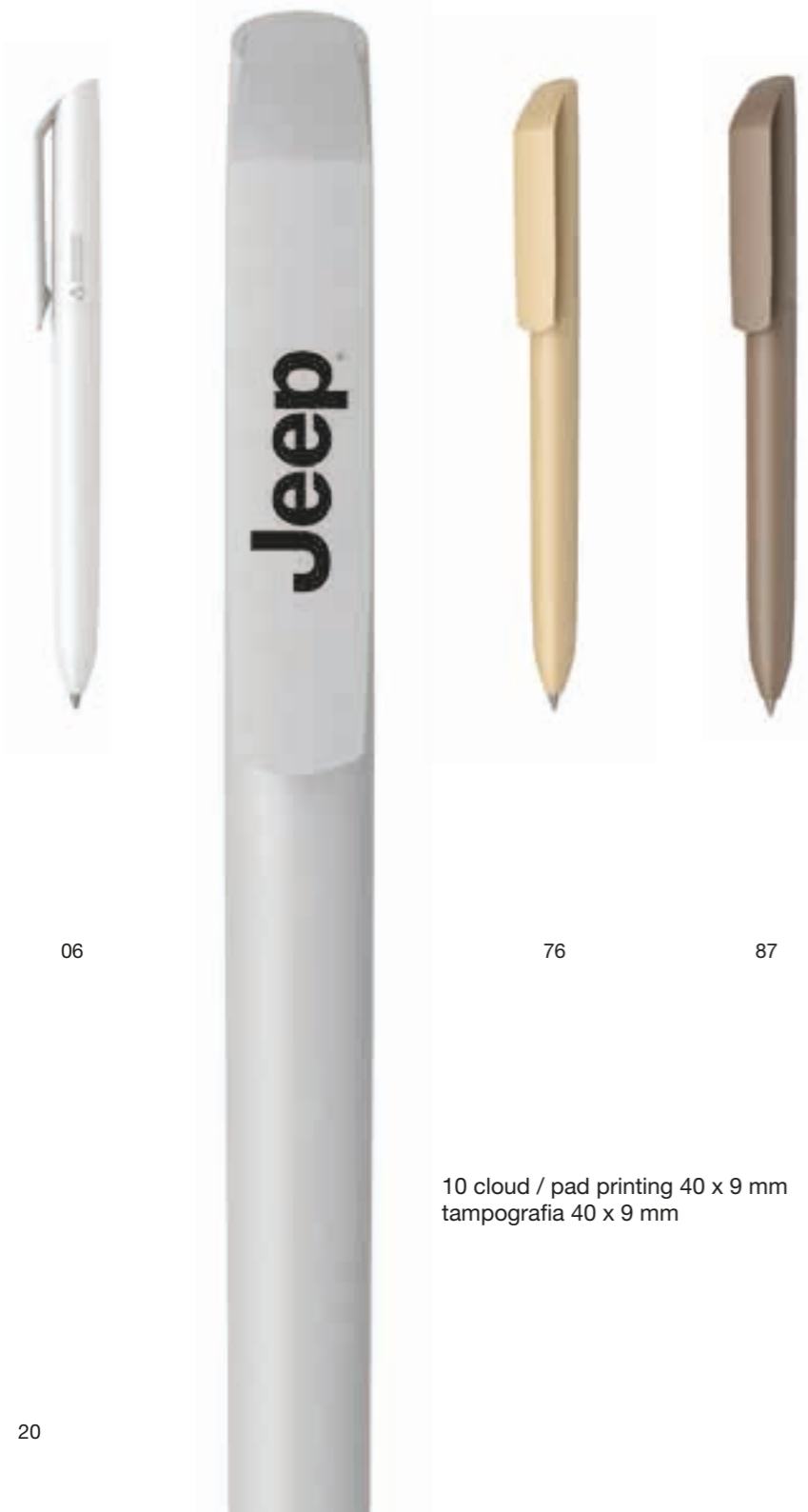

06

76

87

10 cloud / pad printing 40 x 9 mm
tampografia 40 x 9 mm

Plastica riciclata
Colori coprenti con finitura satinata

Per un consumo
responsabile: più
qualità, meno
quantità.



21

58

07

19 forest / pad printing 40 x 9 mm
tampografia 40 x 9 mm

Dot

△ RECYCLED

Different from the rest, full stop.
Diversa da tutte, punto.

A pen that reveals its originality in its details.

È nei dettagli che rivela la sua originalità.

NEW

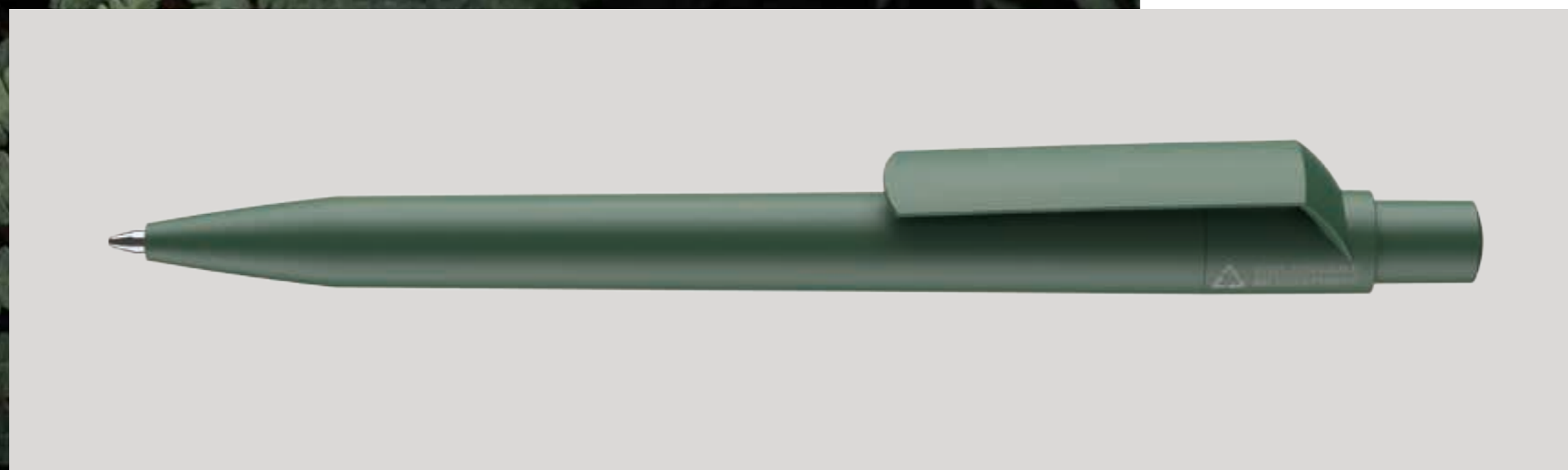

QUALITY NOT QUANTITY

The entire Maxema collection is available in recycled plastic on request /
Tutta la collezione Maxema è realizzabile in plastica riciclata su richiesta

Technical information at p. 233
Informazioni tecniche a pag. 233

D1 MATT CB RE

Recycled plastic
Solid colour barrel with matt finish,
solid matt white clip and push-button,
solid glossy white little sphere

NEW



10

76

87



MY BOX RECYCLED

Universal reclosable single pen box
in recycled Fedrigoni paper.
Info at p. 248

*Astuccio universale richiudibile per
penna singola in cartoncino riciclato
Fedrigoni.
Info pag. 248*



19

58

07

21 abyss / pad printing 40 x 9 mm
tampografia 40 x 9 mm

Plastica riciclata
Fusto in colore coprente con finitura
satinata, clip e tappino in colore
bianco coprente satinato, piccola
sfera in colore bianco coprente lucido

Recycled plastic
Solid colours with matt finish,
solid glossy colour little sphere

The beauty
of sustainability:
8 new colour
shades inspired
by nature.

NEW



06 ice / pad printing 40 x 9 mm
tampografia 40 x 9 mm



58 graphite / pad printing 40 x 9 mm
tampografia 40 x 9 mm

Plastica riciclata
Colori coprenti con finitura satinata,
piccola sfera in colore coprente lucido

La bellezza
della sostenibilità:
8 nuove
sfumature
di colore ispirate
alla natura.

Zink

△ RECYCLED

Solid geometries.
Solide geometrie.

A pen with a clean-cut
profile and strong
personality.

*Una penna dal profilo
tagliente e dal carattere
deciso.*

NEW



QUALITY NOT
QUANTITY

The entire Maxema collection is available in recycled plastic on request /
Tutta la collezione Maxema è realizzabile in plastica riciclata su richiesta

Technical information at p. 234
Informazioni tecniche a pag. 234

Recycled plastic
Solid colours barrel, solid white
colour cap, glossy finishes

Elegance and
environmental
friendliness:
uncompromisingly
together.

NEW



10



76



87



19



58



07

21 abyss / pad printing 43 x 9 mm
tampografia 43 x 9 mm

Plastica riciclata
Fusto in colori coprenti, cappuccio in
colore bianco coprente, finiture lucide

Eleganza e
attenzione per
l'ambiente: insieme
senza compromessi.

Recycled plastic
Solid colours with glossy finish

NEW



06



10 cloud / pad printing 43 x 9 mm
tampografia 43 x 9 mm



76



87



MY BOX RECYCLED

Universal reclosable single pen box
in recycled Fedrigoni paper.
Info at p. 248

*Astuccio universale richiudibile per
penna singola in cartoncino riciclato
Fedrigoni.
Info pag. 248*



19



21



58

07 onyx / pad printing 43 x 9 mm
tampografia 43 x 9 mm



Plastica riciclata
Colori coprenti con finitura lucida

Pixel

△ RECYCLED

High resolution design.
Il design ad alta definizione.

A synthesis
of contemporary style.

*Sintesi dello stile
contemporaneo.*

NEW



QUALITY NOT QUANTITY

The entire Maxema collection is available in recycled plastic on request /
Tutta la collezione Maxema è realizzabile in plastica riciclata su richiesta

Technical information at p. 242
Informazioni tecniche a pag. 242

PX40 | MATT CB RE

Recycled plastic
Solid colour barrel with matt finish,
solid glossy white colour clip
and push-button

NEW



10



76 desert / pad printing 30 x 8 mm
tampografia 30 x 8 mm



87



19



21



58 graphite / pad printing 30 x 8 mm
tampografia 30 x 8 mm



07

Plastica riciclata
Fusto in colore coprente con finitura
satinata, clip e tappino in colore
bianco coprente con finitura lucida



MY BOX RECYCLED

Universal reclosable single pen box
in recycled Fedrigoni paper.
Info at p. 248

*Astuccio universale richiudibile per
penna singola in cartoncino riciclato
Fedrigoni.
Info pag. 248*

PX40 | MATT RE

06



10

76

87

Recycled plastic
Solid colour barrel with matt finish,
solid glossy colour clip and push-button

Guaranteed
and certified
recycled plastic
of European origin.

NEW



21

58

07

19 forest / pad printing 30 x 8 mm
tampografia 30 x 8 mm

Plastica riciclata
Fusto in colore coprente
con finitura satinata, clip e tappino
in colore coprente con finitura lucida

Plastica riciclata
di provenienza
europea, garantita
e certificata.

Bay

△ RECYCLED

Casual and attractive.
Disinvolta e accattivante.

Draws attention
for its simplicity.

*Attrae per
la sua semplicità.*

NEW

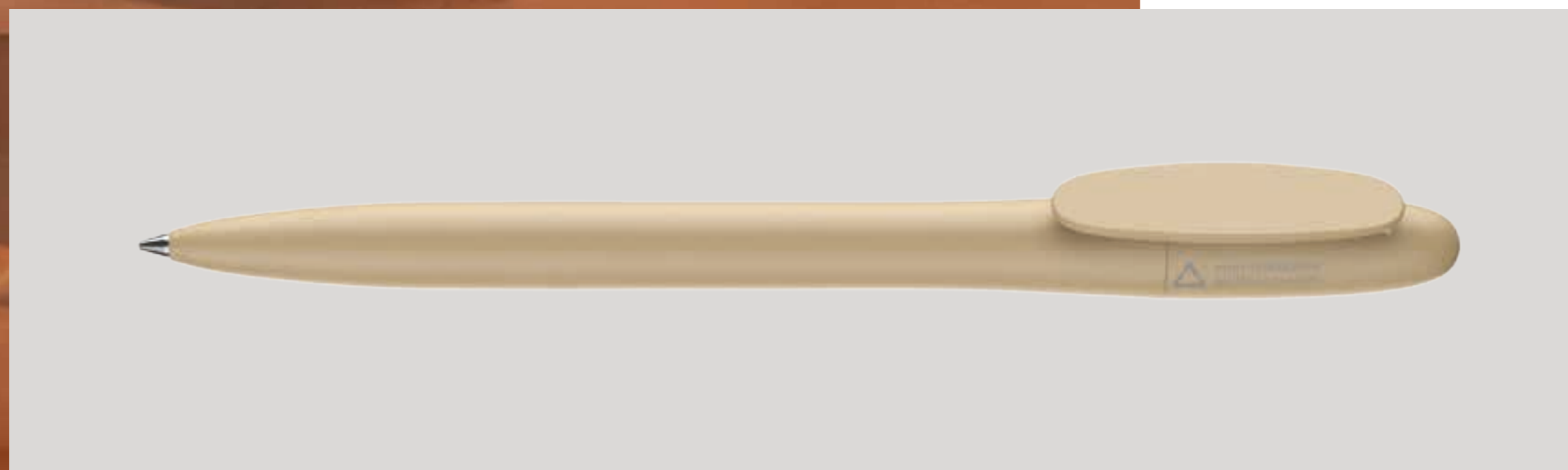

QUALITY NOT QUANTITY

The entire Maxema collection is available in recycled plastic on request /
Tutta la collezione Maxema è realizzabile in plastica riciclata su richiesta

Technical information at p. 243
Informazioni tecniche a pag. 243

Recycled plastic
Solid colours with matt finish

Change is a
choice and it
depends on
each of us.

NEW



06

10

76

87



19

21



58 graphite / pad printing 30 x 7 mm
tampografia 30 x 7 mm



07

Plastica riciclata
Colori coprenti con finitura satinata

Il cambiamento
è una scelta
e dipende
da ognuno di noi.



MY BOX RECYCLED

Universal reclosable single pen box
in recycled Fedrigoni paper.
Info at p. 248

*Astuccio universale richiudibile per penna
singola in cartoncino riciclato Fedrigoni.
Info pag. 248*



The entire Maxema collection is available in recycled plastic on request.*

—
*Tutta la collezione Maxema è realizzabile in plastica riciclata su richiesta.**

*On orders over 10,000 units. / Per ordini superiori alle 10.000 unità.

Mood Metal

Design with a metal touch.
Il design incontra il metallo.

Luxury is a state of mind.
Il lusso è un'attitudine.

NEW
VERSION



The entire Maxema collection is available in recycled plastic on request /
Tutta la collezione Maxema è realizzabile in plastica riciclata su richiesta

Technical information at p. 228
Informazioni tecniche a pag. 228

Chrome finish metal barrel, tip and push-button, solid colour clip with glossy finish

Metal details with diamond mirror finish.

NEW



01 70 03 18 15



74 burgundy / pad printing 40 x 9 mm
74 bordeaux / tampografia 40 x 9 mm



60 61 71 25 72 73

MY BOX

All Mood Metal models come with a single My Box case in black Fedrigoni cardboard included. Info at p. 247

Tutti i modelli Mood Metal vengono forniti con astuccio singolo My Box in cartoncino nero Fedrigoni incluso. Info pag. 247

Fusto, punta e tappino in metallo con finitura cromata, clip in colore coprente lucido

Finitura a specchio diamantata per i particolari in metallo.

75 dark green / pad printing 40 x 9 mm
75 verde scuro / tampografia 40 x 9 mm



79 09



26 27 64 77 12 22 05 04

MD1 | M M4

Titanium grey finish metal barrel, tip and push-button, solid colour clip with glossy finish

New titanium grey finish: metal in a dynamic version.

NEW



70 03 18 15 74 60 61 72

01 white / pad printing 40 x 9 mm
01 bianco / tampografia 40 x 9 mm

MY BOX

All Mood Metal models come with a single My Box case in black Fedrigoni cardboard included. Info at p. 247

Tutti i modelli Mood Metal vengono forniti con astuccio singolo My Box in cartoncino nero Fedrigoni incluso. Info pag. 247

Fusto, punta e tappino in metallo con finitura grigio titanio, clip in colore coprente lucido

Nuova finitura grigio titanio: il metallo in versione dinamica.

04 black / pad printing 40 x 9 mm
04 nero / tampografia 40 x 9 mm



73 79 09 75 27 77 22 05



MD1 | M M2

01 white / pad printing 40 x 9 mm
01 bianco / tampografia 40 x 9 mm



Gold finish metal barrel, tip and push-button, solid colour clip with glossy finish

Metal with gold finish: pure light.

NEW

MY BOX

All Mood Metal models come with a single My Box case in black Fedrigoni cardboard included. Info at p. 247

Tutti i modelli Mood Metal vengono forniti con astuccio singolo My Box in cartoncino nero Fedrigoni incluso. Info pag. 247

04 black / pad printing 40 x 9 mm
04 nero / tampografia 40 x 9 mm



Fusto, punta e tappino in metallo con finitura dorata, clip in colore coprente lucido

Metallo con finitura oro: luce allo stato puro.

Mood

Design with a metal touch.
Il design incontra il metallo.

Luxury is a state of mind.
Il lusso è un'attitudine.



The entire Maxema collection is available in recycled plastic on request /
Tutta la collezione Maxema è realizzabile in plastica riciclata su richiesta

Technical information at p. 229
Informazioni tecniche a pag. 229

Solid colours with glossy finish,
chrome finish metal tip and push-button

Fast Dry Gel

Blue and black
Fast Dry Gel ink
refills available for
all Mood versions.

Colori coprenti con finitura lucida,
punta e tappino in metallo
con finitura cromata

Fast Dry Gel

Refill gel Fast
Dry blu e nero
disponibili su
richiesta per tutte
le versioni Mood.



01 70 03 18 15

74 burgundy / pad printing 40 x 9 mm
74 bordeaux / tampografia 40 x 9 mm



60 61 71 25 72

MY BOX

All Mood models come with a single
My Box case in black Fedrigoni
cardboard included.
Info at p. 247

*Tutti i modelli Mood vengono forniti
con astuccio singolo My Box in
cartoncino nero Fedrigoni incluso.
Info pag. 247*



73 79 09 75 26

27 octan green / pad printing 40 x 9 mm
27 ottanio / tampografia 40 x 9 mm



64 77 12 22 05 04



MD1 | GOM CB M1

Solid colour barrel with rubber finish,
solid glossy white colour clip,
chrome finish metal tip and push-button

18 orange / pad printing 40 x 9 mm
18 arancio / tampografia 40 x 9 mm



60 pink / pad printing 40 x 9 mm
60 rosa / tampografia 40 x 9 mm

Fusto in colore coprente gommato,
clip in colore bianco lucido, punta
e tappino in metallo con finitura
cromata

75 dark green / pad printing 40 x 9 mm
75 verde scuro / tampografia 40 x 9 mm



MY BOX

All Mood models come with a single
My Box case in black Fedrigoni
cardboard included.
Info at p. 247

*Tutti i modelli Mood vengono forniti
con astuccio singolo My Box in
cartoncino nero Fedrigoni incluso.
Info pag. 247*

MD1 | GOM C M1

Solid colour barrel with rubber finish,
solid colour clip with glossy finish,
chrome finish metal tip and push-button

Result of
superior quality
craftsmanship.

Fusto in colore coprente gommato,
clip in colore coprente con finitura
lucida, punta e tappino in metallo
con finitura cromata

Risultato
di lavorazioni
artigiane di
qualità superiore.



70 03 18 15 74 60 61 71 25 72 73



79 09 75 26 27 64 77 12 22 05



04 black / pad printing 40 x 9 mm
04 nero / tampografia 40 x 9 mm

MY BOX

All Mood models come with a single
My Box case in black Fedrigoni
cardboard included.
Info at p. 247

*Tutti i modelli Mood vengono forniti
con astuccio singolo My Box in
cartoncino nero Fedrigoni incluso.
Info pag. 247*

MD1 | GOM 30 M1

Solid colour barrel with rubber finish, transparent colour clip with glossy finish, chrome finish metal tip and push-button

31 light violet / pad printing 40 x 9 mm
31 viola chiaro / tampografia 40 x 9 mm



39

53

45

59

41

55

37

52 yellow / pad printing 40 x 9 mm
52 giallo / tampografia 40 x 9 mm



38



49

47

34

67

44

30

50

78 lime / pad printing 40 x 9 mm
78 lime / tampografia 40 x 9 mm

Fusto in colore coprente gommato, clip in colore trasparente con finitura lucida, punta e tappino in metallo con finitura cromata

MY BOX

All Mood models come with a single My Box case in black Fedrigoni cardboard included.
Info at p. 247

Tutti i modelli Mood vengono forniti con astuccio singolo My Box in cartoncino nero Fedrigoni incluso. Info pag. 247

MD1 | C M2

Solid colours with glossy finish, gold finish metal tip and push-button

Colori coprenti con finitura lucida, punta e tappino in metallo con finitura dorata



01

04 black / pad printing 40 x 9 mm
04 nero / tampografia 40 x 9 mm



MD1 | C M3

Solid colours with glossy finish, rose gold metal tip and push button

Colori coprenti con finitura lucida, punta e tappino in metallo con finitura oro rosa



01

04 black / pad printing 40 x 9 mm
04 nero / tampografia 40 x 9 mm



Rose gold, in line with the colour trends of the moment.

NEW

Oro rosa, in linea con i trend cromatici del momento.

MY BOX

All Mood models come with a single My Box case in black Fedrigoni cardboard included.
Info at p. 247

*Tutti i modelli Mood vengono forniti con astuccio singolo My Box in cartoncino nero Fedrigoni incluso.
Info pag. 247*

Icon Pure

All over soft touch.
Soft touch integrale.

All-round personality.
Personalità a tutto tondo.

NEW



The entire Maxema collection is available in recycled plastic on request /
Tutta la collezione Maxema è realizzabile in plastica riciclata su richiesta

Technical information at p. 230
Informazioni tecniche a pag. 230

Solid colours with rubber finish

Full rubber coating on the entire pen: for printing recommendations, please refer to the technical data sheet on page 230.

NEW



01 03



15 74 60 61

18 orange / pad printing 35 x 7 mm
18 arancio / tampografia 35 x 7 mm



71 25 72 73

Colori coprenti con finitura gommata

Gommatura integrale su tutta la penna: per i consigli di stampa consultare la scheda tecnica a pag. 230

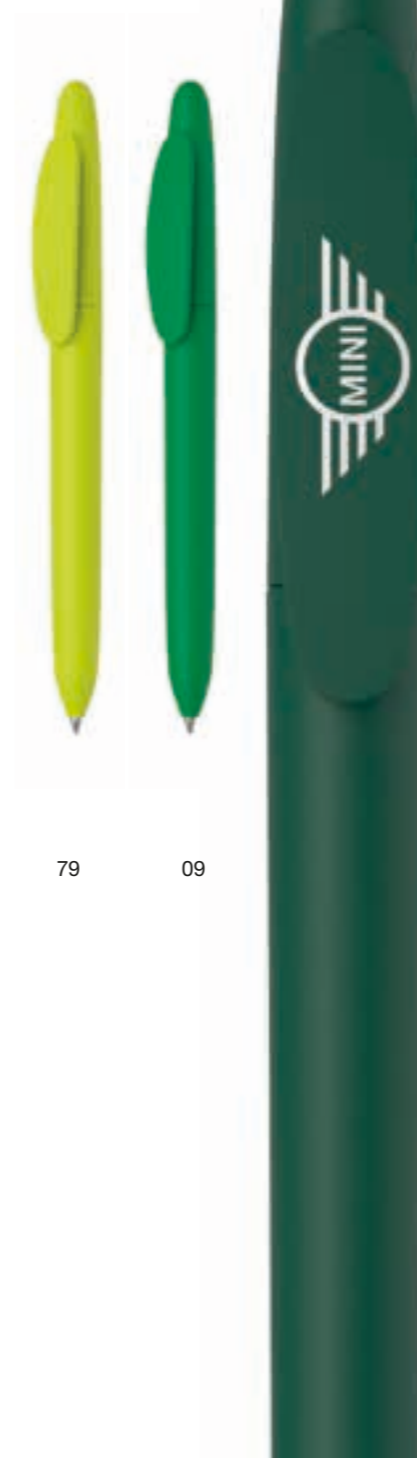

79 09



26 27 64 77

75 dark green / pad printing 35 x 7 mm
75 verde scuro / tampografia 35 x 7 mm



12 22 05 04

Flow Pure

Free from extra.
Pura ed essenziale.

The essence of design.
L'essenza del design.



The entire Maxema collection is available in recycled plastic on request /
Tutta la collezione Maxema è realizzabile in plastica riciclata su richiesta

Technical information at p. 231
Informazioni tecniche a pag. 231

Solid colour barrel and cap with rubber finish, solid colour clip with matt finish

Soft touch with matt finish is the new single-colour combination.

NEW



01

03

15

74

60

61

71

25

73

79

18 orange / pad printing 40 x 9 mm
18 arancio / tampografia 40 x 9 mm

Fusto e cappuccio in colore coprente gommato, clip in colore coprente satinato

Soft touch con satinato è il nuovo abbinamento in versione monocromatica.



09

75

27

64

77

12

22

05

04

26 aquamarine / pad printing 40 x 9 mm
26 acquamarina / tampografia 40 x 9 mm

F2P | MATT CB

Solid colour barrel and cap, solid white colour clip, matt finishes

Matt finish and white clip for maximum freedom of personalisation.



70 03 18 15 74 60 61 71 25 72 73 79

Fusto e cappuccio in colore coprente, clip in colore bianco coprente, finiture satinat

Finitura matt e clip bianca per la massima libertà di personalizzazione.



09 75 26 27 64 77 12 22

05 grey / pad printing 40 x 9 mm
05 grigio / tampografia 40 x 9 mm

Solid colours with matt finish

All the expressive force of colour in a matt version.

Colori coprenti con finitura satinata

Tutta la forza espressiva del colore in versione satinata.



01 70 03 18 15 74 60 61

71 light violet / pad printing 40 x 9 mm
71 viola chiaro / tampografia 40 x 9 mm



25 72 73



79 09 75 26 27 64 77 12

22 blue / pad printing 40 x 9 mm
22 blu / tampografia 40 x 9 mm



05 04

Solid fluo colours with matt finish

The matt finish lights up with fluo colours.

FLUO



02



17 orange / pad printing 40 x 9 mm
17 arancio / tampografia 40 x 9 mm



14



56 fuchsia / pad printing 40 x 9 mm
56 fucsia / tampografia 40 x 9 mm



08

Colori fluo coprenti con finitura satinata

La finitura satinata si accende con i colori fluo.

Solid colours with glossy finish

The colours stand out due to the brilliance of the gloss finish.

Colori coprenti con finitura lucida

I colori risaltano grazie alla brillantezza della finitura lucida.



01 70 03 18 15 74



60 pink / pad printing 40 x 9 mm
60 rosa / tampografia 40 x 9 mm



61 71 25 72



73 79 09 75 26 27 64 77 12 22 05 04

F2P | GOM K

Solid black barrel and cap with rubber finish, solid colour clip with glossy finish

Fusto e cappuccio in colore nero coprente gommato, clip in colore coprente lucido



70 cream / pad printing 40 x 9 mm
70 crema / tampografia 40 x 9 mm



03



18 orange / pad printing 40 x 9 mm
18 arancio / tampografia 40 x 9 mm



15



60



61



71



72



79



09



27



64



77



12



05



04

26 aquamarine / pad printing 40 x 9 mm
26 acquamarina / tampografia 40 x 9 mm

F2P | GOM CB

60 pink / pad printing 40 x 9 mm
60 rosa / tampografia 40 x 9 mm

Solid colour barrel and cap with rubber finish, solid white colour clip with glossy finish

Rubberised all over: soft touch barrel and cap.

Fusto e cappuccio in colore coprente gommato, clip in colore bianco coprente lucido

Gommatura integrale: fusto e cappuccio soft touch.



01 03 18 15 74



61



25 73

71 light violet / pad printing 40 x 9 mm
71 viola chiaro / tampografia 40 x 9 mm

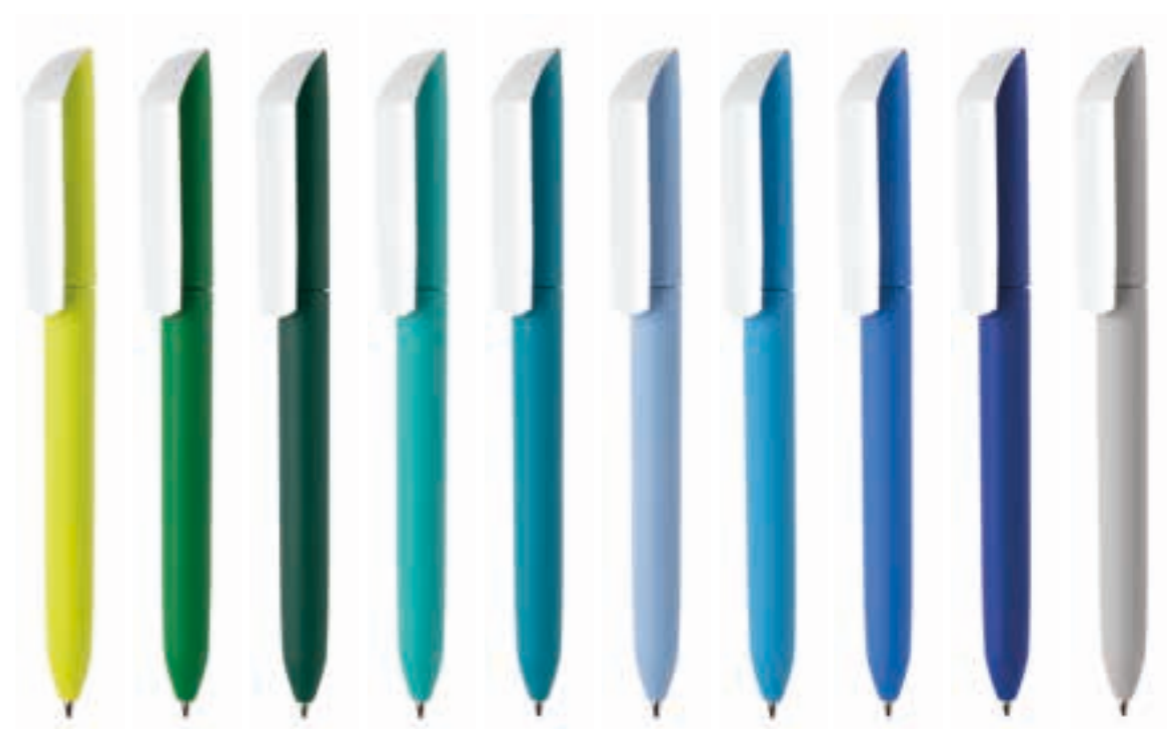

79 09 75 26 27 64 77 12 22 05

04 black / pad printing 40 x 9 mm
04 nero / tampografia 40 x 9 mm



Solid colour barrel and cap with rubber finish, transparent colour clip with glossy finish

Even the rubberised barrel can be pad or silk-screen printed.



39 52 53 45 59 41 31 55 37

38 brown / pad printing 40 x 9 mm
38 marrone / tampografia 40 x 9 mm



Fusto e cappuccio in colore coprente gommato, clip in colore trasparente lucido

Anche il fusto è stampabile con tampografia o serigrafia.



78



49 green / pad printing 50 x 9 mm
49 verde / tampografia 50 x 9 mm



47 34 67 44 30

50 dark grey / pad printing 40 x 9 mm
50 grigio scuro / tampografia 40 x 9 mm



F2P | GOM CF

Solid fluo colour barrel and cap with rubber finish, solid fluo colour clip with glossy finish

FLUO



02

17

14

56 fuchsia / pad printing 40 x 9 mm
56 fucsia / tampografia 40 x 9 mm



08

F2P | GOM KF

Fusto e cappuccio in colore nero coprente gommato, clip in colore fluo coprente lucido

FLUO

02 yellow / pad printing 40 x 9 mm
02 giallo / tampografia 40 x 9 mm



17



56



08

14 coral red / pad printing 40 x 9 mm
14 rosso corallo / tampografia 40 x 9 mm

Solid fluo colour barrel and cap with rubber finish, transparent fluo colour clip with glossy finish.

Minimal profile and compact volumes.

FLUO



MY BOX

Universal reclosable single pen box in Fedrigoni black card. Info at p. 247

Astuccio universale richiudibile per penna singola in cartoncino nero Fedrigoni. Info pag. 247



20



33 orange / pad printing 40 x 9 mm
33 arancio / tampografia 40 x 9 mm



24



46

48 green / pad printing 40 x 9 mm
48 verde / tampografia 40 x 9 mm



Fusto e cappuccio in colore fluo coprente gommato, clip in colore fluo trasparente lucido.

Profilo minimal e volumi compatti.

FLUO

Flow

Feel the change.
Senti il cambiamento.

Evolution of shape,
with and without texturing.

*L'evoluzione della forma,
con e senza texture.*



The entire Maxema collection is available in recycled plastic on request /
Tutta la collezione Maxema è realizzabile in plastica riciclata su richiesta

Technical information at p. 232
Informazioni tecniche a pag. 232

F1 MATT AL

Solid colours with matt finish,
aluminium painted finish tip

Matt colours
and aluminium
colour tip: satin
style elegance.



01 70 03 18 15 74 60 61 71 25 73

Colori coprenti con finitura
satinata, punta verniciata
in colore alluminio

Colori matt
e punta color
alluminio:
eleganza in
versione satinata.

79 lime / pad printing 40 x 9 mm
79 lime / tampografia 40 x 9 mm



09 75 26 27 64

77 cyan / pad printing 40 x 9 mm
77 ciano / tampografia 40 x 9 mm



12 22 05 04

Solid colours with glossy finish,
chromed tip

Colori coprenti con finitura lucida,
punta cromata



70 03 18 15 74 60 61 71 25 73

01 white / pad printing 40 x 9 mm
01 bianco / tampografia 40 x 9 mm

77 cyan / pad printing 40 x 9 mm
77 ciano / tampografia 40 x 9 mm



79 09 75 26 27 64

77 cyan / pad printing 46 x 9 mm
77 ciano / tampografia 46 x 9 mm



12 22 05 04

F1T | GOM C CR

Solid colour barrel with rubber finish, solid colour clip with glossy finish, textured solid colour cap with matt finish, chromed tip

Distinctive feature: textured cap.

Fusto in colore coprente gommato, clip in colore coprente lucido, cappuccio texturizzato in colore coprente con finitura satinata, punta cromata

Elemento distintivo: cappuccio arricchito da una texture.



01 70 03



15 74 60 61 71 25 73

18 orange / pad printing 40 x 9 mm
18 arancio / tampografia 40 x 9 mm



79 09 75 26 27 64 77 12 22 05

04 black / pad printing 40 x 9 mm
04 nero / tampografia 40 x 9 mm



F1T | GOM CB CR

Solid colour barrel with rubber finish, solid glossy white colour clip, textured solid colour cap with matt finish, chromed tip

Textured with small hexagonal cells that recall a honeycomb: a dynamic design of visual and tactile elegance.

Fusto in colore coprente gommato, clip in colore bianco lucido, cappuccio texturizzato in colore coprente con finitura satinata, punta cromata

Texture costituita da piccole celle esagonali che ricordano un nido d'ape: un design dinamico che dona eleganza visiva e tattile.

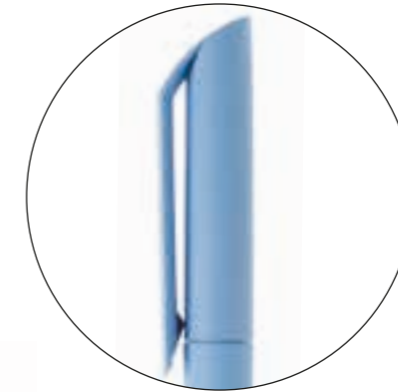

03 18 15 74 60 61 71 25

79

09 75

27 64 77 12 22

04

73 brown / pad printing 40 x 9 mm
73 marrone / tampografia 40 x 9 mm

26 aquamarine / pad printing 40 x 9 mm
26 acquamarina / tampografia 40 x 9 mm

05 grey / pad printing 40 x 9 mm
05 grigio / tampografia 40 x 9 mm

F1T | GOM 30 CR

Solid colour barrel with rubber finish, transparent glossy colour clip, textured solid colour cap with matt finish, chromed tip



39 52 53 45

59 pink / pad printing 40 x 9 mm
59 rosa / tampografia 40 x 9 mm



41 31 55 37



38 78 49 47

34 pastel blue / pad printing 40 x 9 mm
34 azzurro pastello / tampografia 40 x 9 mm



67 44 50

Fusto in colore coprente gommato, clip in colore trasparente lucido, cappuccio texturizzato in colore coprente con finitura satinata, punta cromata

30 light grey / pad printing 40 x 9 mm
30 grigio chiaro / tampografia 40 x 9 mm

Dot

Different from the rest, full stop.
Diversa da tutte, punto.

A pen that reveals
its originality in its details.
*È nei dettagli che rivela
la sua originalità.*



The entire Maxema collection is available in recycled plastic on request /
Tutta la collezione Maxema è realizzabile in plastica riciclata su richiesta

Technical information at p. 233
Informazioni tecniche a pag. 233

Solid white colour barrel, clip and push-button with matt finish, solid glossy colour little sphere

The matt finish enhances the design and offers new tactile sensations.

The touch of colour stands out against the pure white.



01

03 yellow / pad printing 40 x 9 mm
03 giallo / tampografia 40 x 9 mm



Fusto, clip e tappino in colore bianco coprente con finitura satinata, piccola sfera in colore coprente lucido

La finitura satinata esalta il design e offre nuove sensazioni tattili.

Il punto di colore spicca nella nitidezza del bianco.

D1 MATT CB

Solid colour barrel with matt finish, solid matt white clip and push-button, solid glossy colour little sphere

Fusto in colore coprente con finitura satinata, clip e tappino in colore bianco coprente satinato, piccola sfera in colore coprente lucido



03 18 15 74

61 71 25 73

60 pink / pad printing 40 x 9 mm
60 rosa / tampografia 40 x 9 mm



79 09 75 26 27 64 77

22 05 04

12 light blue / pad printing 40 x 9 mm
12 azzurro / tampografia 40 x 9 mm

D1 MATT

Solid colours with matt finish, solid glossy colour little sphere

Attractive and refined: the integral matt finish.

Colori coprenti con finitura satinata, piccola sfera in colore coprente lucido

Attraente e raffinata: è la finitura satinata integrale.



70 03 18 15 74 60 61

71 light violet / pad printing 40 x 9 mm
71 viola chiaro / tampografia 40 x 9 mm



25 72 73



79 09 75 26 27 64 77 12 22 05

04 black / pad printing 40 x 9 mm
04 nero / tampografia 40 x 9 mm



Solid black colour barrel, clip and push-button with matt finish, solid glossy colour little sphere

Purity of lines and matt finish: simply elegant.

Minimal black is combined with a discreet touch of colour.



01



70 cream / pad printing 40 x 9 mm
70 crema / tampografia 40 x 9 mm

Fusto, clip e tappino in colore nero coprente con finitura satinata, piccola sfera in colore coprente lucido

Purezza di linee e finitura matt: semplicemente elegante.

Il nero minimal è abbinato a una piccola e discreta nota di colore.

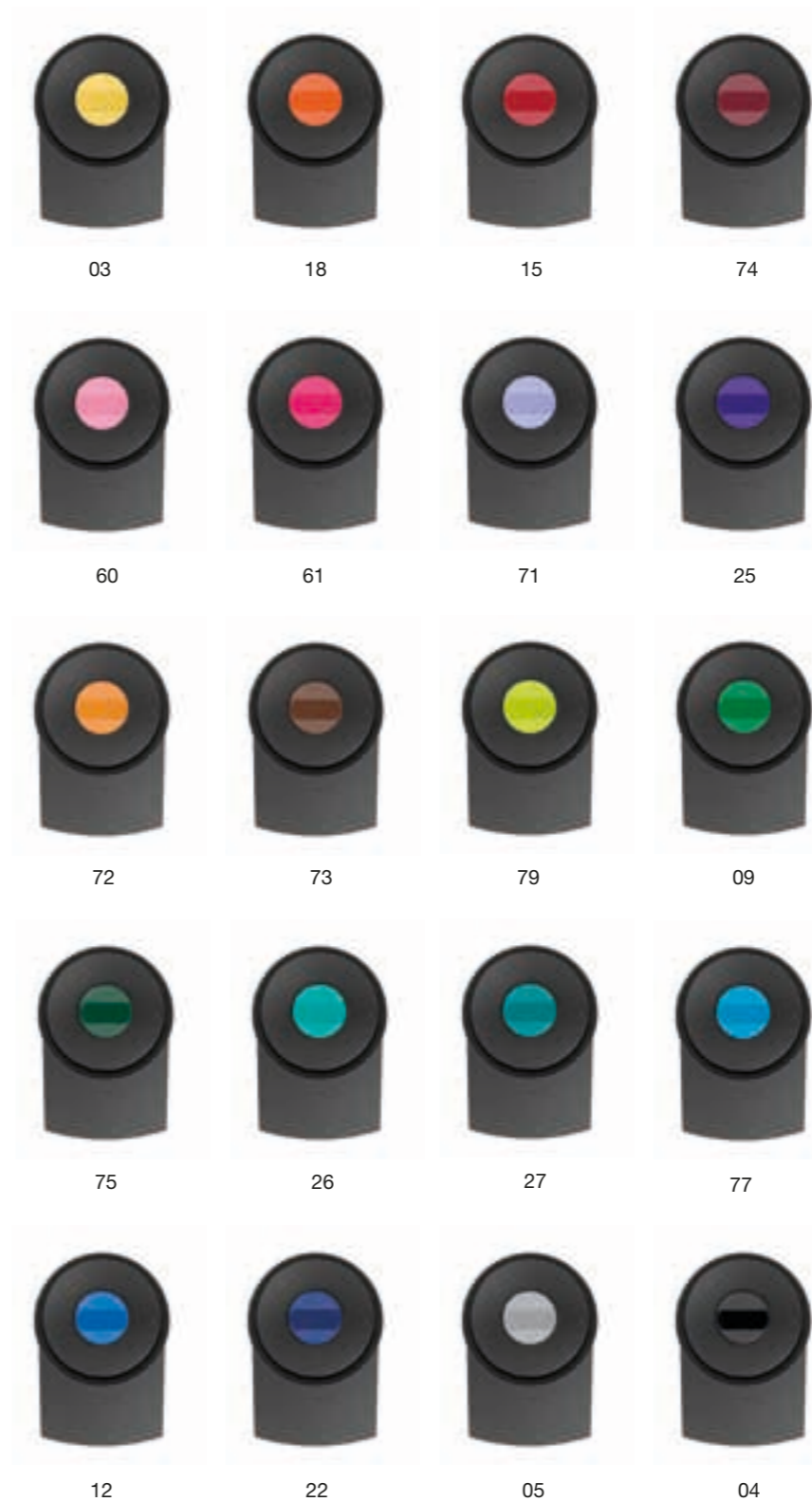

Solid fluo colours with matt finish,
solid glossy fluo colour little sphere

A more profound
chromatic impact
thanks to the fluo
colours.

FLUO



02



17

Colori fluo coprenti con finitura
satinata, piccola sfera in colore fluo
coprente lucido

Impatto cromatico
più incisivo
grazie ai colori
fluo.

FLUO



56



08

14 coral red / pad printing 40 x 9 mm
14 rosso corallo / tampografia 40 x 9 mm

Solid white colour barrel and clip with glossy finish, solid glossy colour little sphere, chromed push-button

A white surface is the creative foundation par excellence: freedom of expression and top colour rendering.

Total white: basic and elegant thanks to its refined colour detail.



01

03 yellow / pad printing 40 x 9 mm
03 giallo / tampografia 40 x 9 mm



Fusto e clip in colore bianco coprente con finitura lucida, piccola sfera in colore coprente lucido, tappino cromato

La superficie bianca è la base creativa per eccellenza: libertà di espressione e massima resa cromatica.

Total white: essenziale ed elegante grazie al raffinato dettaglio di colore.



18



15



74



60



61



71



25



73



79



09



75



27



64



77



12



22



05



04

D1 CB CR

Solid colour barrel and little sphere with glossy finish, solid glossy white colour clip, chromed push-button

Fusto e piccola sfera coprente lucido, clip in colore bianco coprente lucido, tappino cromato



03

18



74

60

61

71

25

73

79

15 red / pad printing 40 x 9 mm
15 rosso / tampografia 40 x 9 mm



09

75

27

64

77

12

22

05

04 black / pad printing 40 x 9 mm
04 nero / tampografia 40 x 9 mm



D1 | C CR

Solid colours with glossy finish,
chromed push-button

Colori coprenti con finitura lucida,
tappino cromato

74 burgundy / pad printing 40 x 9 mm
74 bordeaux / tampografia 40 x 9 mm

64 pastel blue / pad printing 40 x 9 mm
64 azzurro pastello / tampografia 40 x 9 mm



70

03

15

60

61

71

25

73

79

09

75

27

77

12

22

05

18 orange /
pad printing
40 x 9 mm
18 arancio /
tampografia
40 x 9 mm

04 black /
pad printing
40 x 9 mm
04 nero /
tampografia
40 x 9 mm

D1 30 CR

Transparent colours with glossy finish, solid glossy colour little sphere, chromed push-button

Colori trasparenti con finitura lucida, piccola sfera in colore coprente lucido, tappino cromato



39



52 yellow / pad printing 40 x 9 mm
52 giallo / tampografia 40 x 9 mm



53

45

41

55

37

38



78 lime /
pad printing
40 x 9 mm
78 lime /
tampografia
40 x 9 mm



49

47

67

44

50

Solid black colour barrel with rubber finish, solid black colour clip and push-button with glossy finish, solid glossy colour little sphere

The elegance of black combines with a soft touch finish for a high-impact result.



01



70 cream / pad printing 40 x 9 mm
70 crema / tampografia 40 x 9 mm

Total black with a note of colour.

Fusto in colore nero coprente gommato, clip e tappino in colore nero coprente lucido, piccola sfera in colore coprente lucido

L'eleganza del nero si combina con la finitura soft touch per un risultato di grande impatto.



03



18



15



74



60



61



71



25



72



73



79



09



75



26



27



77



12



22



05



04

Total black con nota di colore.

Solid colour barrel with rubber finish, solid glossy white colour clip, solid glossy colour little sphere, chromed push-button



01 03



15 74 60 61 71

18 orange /
pad printing
40 x 9 mm
18 arancio /
tampografia
40 x 9 mm

25 dark violet /
pad printing
40 x 9 mm
25 viola scuro /
tampografia
40 x 9 mm



73

64 pastel blue / pad printing 40 x 9 mm
64 azzurro pastello / tampografia 40 x 9 mm



79 09 75 26 27



77 12 22

05 grey /
pad printing
40 x 9 mm
05 grigio /
tampografia
40 x 9 mm



04

Fusto in colore coprente gommato, clip in colore bianco coprente lucido, piccola sfera in colore coprente lucido, tappino cromato

D1 | GOM C CR

Solid colour barrel with rubber finish, solid colour clip and little sphere with glossy finish, chromed push-button

Fusto in colore coprente gommato, clip e piccola sfera in colore coprente con finitura lucida, tappino cromato



71 light violet / pad printing 40 x 9 mm
71 viola chiaro / tampografia 40 x 9 mm



18 15 74 60 61



25 72 73



79 09 75 27 64 77 12

22 blue / pad printing 40 x 9 mm
22 blu / tampografia 40 x 9 mm



05 04

03 yellow / pad printing 40 x 9 mm
03 giallo / tampografia 40 x 9 mm

D1 | GOM 30 CR

Solid colour barrel with rubber finish, transparent colour clip with glossy finish, solid glossy colour little sphere, chromed push-button



39 52 53 45 59 41 31 55 37

38 brown / pad printing 40 x 9 mm
38 marrone / tampografia 40 x 9 mm

Fusto in colore coprente gommato, clip in colore trasparente con finitura lucida, piccola sfera in colore coprente lucido, tappino cromato



78 49 47 34 67 44 30

50 dark grey / pad printing 40 x 9 mm
50 grigio scuro / tampografia 40 x 9 mm

D1 | C GOLD

Solid colours with glossy finish,
gilded push-button

*Colori coprenti con finitura lucida,
tappino dorato*



01 white / pad printing 40 x 9 mm
01 bianco / tampografia 40 x 9 mm



04

D1 | GOM KF CR

Solid black colour barrel with rubber
finish, solid fluo colour clip
and little sphere with glossy finish,
chromed push-button

*Fusto in colore nero coprente
gommato, clip e piccola sfera
in colore fluo coprente lucido,
tappino cromato*

FLUO



02

17 orange /
pad printing
40 x 9 mm
17 arancio /
tampografia
40 x 9 mm



56



08

14 coral red / pad printing 40 x 9 mm
14 rosso corallo / tampografia 40 x 9 mm

Zink

Solid geometries.
Solide geometrie.

A pen with a
clean-cut profile
and strong personality.

*Una penna
dal profilo tagliente
e dal carattere deciso.*



The entire Maxema collection is available in recycled plastic on request /
Tutta la collezione Maxema è realizzabile in plastica riciclata su richiesta

Technical information at p. 234
Informazioni tecniche a pag. 234

Solid colours barrel, solid white colour cap, glossy finishes

More suitability for multi-colour printing with white clip.

Fusto in colori coprenti, cappuccio in colore bianco coprente, finiture lucide

Maggiore versatilità per la stampa a più colori con la clip bianca.



70 03 18 15 74



61 71 25 73

60 pink / pad printing 43 x 9 mm
60 rosa / tampografia 43 x 9 mm



79 09 75 26 27 64 77

12 light blue / pad printing 43 x 9 mm
12 azzurro / tampografia 43 x 9 mm



22 05 04

Solid colours with glossy finish

Solid, sturdy architecture for a profile of geometric precision.

Colori coprenti con finitura lucida

Architettura corposa e robusta per un profilo dal rigore geometrico.



01 70 03



18 orange / pad printing 43 x 9 mm
18 arancio / tampografia 43 x 9 mm



15 74 60 61 25 73



79 09 75



64 77 12 22

05 grey / pad printing 43 x 9 mm
05 grigio / tampografia 43 x 9 mm



27 octan green / pad printing 43 x 9 mm
27 ottanio / tampografia 43 x 9 mm



04

Transparent colours with glossy finish

Its sturdy structure is offset by the slim, streamlined barrel.



39 52 53 45 59 41 51 31 55

37 amber / pad printing 43 x 9 mm
37 ambra / tampografia 43 x 9 mm



Colori trasparenti con finitura lucida

Il fusto slanciato bilancia la solida struttura.

67 cyan / pad printing 43 x 9 mm
67 ciano / tampografia 43 x 9 mm



38 78 49 47



44 30 50

Solid fluo colours with glossy finish

Fluo colours,
intense and
vibrant shades.

FLUO



02



17 orange / pad printing 43 x 9 mm
17 arancio / tampografia 43 x 9 mm



14

56

Colori fluo coprenti
con finitura lucida

Colori fluo,
tonalità intense
e vibranti.



08 green / pad printing 43 x 9 mm
08 verde / tampografia 43 x 9 mm

View

Decisive personality.
Carattere incisivo.

Exudes boldness from every angle and captivates with its elegance.

Sprigiona grinta da ogni punto di vista e affascina per l'eleganza.



The entire Maxema collection is available in recycled plastic on request /
Tutta la collezione Maxema è realizzabile in plastica riciclata su richiesta

Technical information at p. 235
Informazioni tecniche a pag. 235

V1 C CR / C CRT

V1 - C CR clip per incisione laser / clip for laser engraving

V1 - C CRT clip per tampografia / clip for pad printing

Solid colours with glossy finish, metal chrome finish clip, chromed tip

Colori coprenti con finitura lucida, clip in metallo cromato, punta cromata



01 70 03 18 15 74

60 pink / laser engraving 30 x 7 mm
60 rosa / incisione laser 30 x 7 mm



61 71



25 73



79 lime / screen printing 42 x 30 mm
79 lime / serigrafia 42 x 30 mm



09 75 27 64 12

22 blue / pad printing on the clip 40 x 6 mm
22 blu / tampografia su clip 40 x 6 mm



04

V1 | 30 CR / 30 CR T

V1 – 30 CR clip per incisione laser /
clip for laser engraving

V1 – 30 CR T
clip per tampografia /
clip for pad printing

Transparent colours with glossy finish,
metal chrome finish clip, chromed tip

*Colori trasparenti con finitura lucida,
clip in metallo cromato, punta cromata*



52 53 45 51 55 49 47 44 40

39 neutral / screen printing 42 x 30 mm
39 neutro / serigrafia 42 x 30 mm

**yourbest
break.com**

V1 | AL CR / AL CR T *

V1 – AL CR clip per incisione laser /
clip for laser engraving

V1 – AL CR T
clip per tampografia /
clip for pad printing

Aluminium painted finish barrel and
cap, metal chromed clip, chromed tip

*Fusto e cappuccio verniciati in colore
alluminio, clip in metallo cromato,
punta cromata*

The sleek design
of the cap adds
elegance
and balances
the large clip.

La linea affilata
del cappuccio dà
armonia e bilancia
l'imponenza
della clip.



aluminium / laser engraving 30 x 7 mm
alluminio / incisione laser 30 x 7 mm

V1 GOM C CR / GOM C CR T

V1 - GOM C CR
clip per incisione laser /
clip for laser engraving

V1 - GOM C CR T
clip per tampografia /
clip for pad printing

Solid colour barrel and cap with
rubber finish, metal chrome clip,
chromed tip

Free rein to
colours on
metals too.

Fusto e cappuccio in colore coprente
gommato, clip in metallo cromato,
punta cromata

Via libera ai colori,
anche su metallo.



03

15

74

60

18 orange /
pad printing on the clip 40 x 6 mm
18 arancio /
tampografia su clip 40 x 6 mm

71

25

72

61 magenta /
screen printing 42 x 30 mm
61 magenta /
serigrafia 42 x 30 mm

73

79

09

75

27

64 pastel blue / laser engraving 30 x 7 mm
64 azzurro pastello / incisione laser 30 x 7 mm

12

22

04 black / pad printing
on the clip 40 x 6 mm
04 nero / tampografia
su clip 40 x 6 mm

Tag

Imposing elegance.
Eleganza imponente.

Clean-cut, refined
design, a tribute
to perfect elegance.

*Design semplice
e raffinato, omaggio
all'eleganza perfetta.*



The entire Maxema collection is available in recycled plastic on request /
Tutta la collezione Maxema è realizzabile in plastica riciclata su richiesta

Technical information at p. 236
Informazioni tecniche a pag. 236

Solid white colour barrel and clip with matt finish, solid colour upper plug with glossy finish, aluminium painted finish tip

01 white / pad printing 40 x 9 mm
 01 bianco / tampografia 40 x 9 mm
 —
 screen printing 42 x 30 mm
 serigrafia 42 x 30 mm



03 18 15 74

61 magenta / pad printing 40 x 9 mm
 61 magenta / tampografia 40 x 9 mm



71 25



72 73 79 09 27

64 pastel blue / pad printing 40 x 9 mm
 64 azzurro pastello / tampografia 40 x 9 mm



12 22 04

Fusto e clip in colore bianco coprente con finitura satinata, tassello superiore in colori coprenti con finitura lucida, punta verniciata in colore alluminio

TA1 | B CR

Solid white colour barrel and clip,
solid colour upper plug, glossy
finishes, chromed tip

Elegance and
linearity to express
all the strength
of a brand.

15 red / pad printing 40 x 9 mm
15 rosso / tampografia 40 x 9 mm



03

18



74

61

09

27

12

22



*Fusto e clip in colore bianco, tassello
superiore in colori coprenti, finiture
lucide, punta cromata*

Eleganza e
linearità per
esprimere tutta la
forza di un brand.

04 black / pad printing 40 x 9 mm
04 nero / tampografia 40 x 9 mm

Solid colours with glossy finish,
chromed upper plug and tip

Colori coprenti con finitura lucida,
tassello superiore e punta cromati

01 white / pad printing 40 x 9 mm
01 bianco / tampografia 40 x 9 mm

64 pastel blue / pad printing 40 x 9 mm
64 azzurro pastello / tampografia 40 x 9 mm



70 03 18 15 74 60 61 71 25 72



79 09 75 27

73 brown / pad printing 40 x 9 mm
73 marrone / tampografia 40 x 9 mm



12 22 04

TA1 | MET AL

Metallic colours painted finish barrel and clip, aluminium painted finish upper plug and tip

Fusto e clip verniciati in colori metallizzati, tassello superiore e punta verniciati in colore alluminio



92

83



85 red / pad printing 40 x 9 mm
85 rosso / tampografia 40 x 9 mm



94

95

96



MY BOX

Universal reclosable single pen box in Fedrigoni black card.
Info at p. 247

Astuccio universale richiudibile per penna singola in cartoncino nero Fedrigoni. Info pag. 247

TA1 | AL CR

Aluminium painted finish barrel and clip, chromium plated upper plug and tip

Fusto e clip verniciati in colore alluminio, tassello superiore e punta cromati

Its rigorous styling is softened by the smooth curve of the clip and closing plug.

Lo stile rigoroso è ingentilito dalla dolce curvatura della clip e del suo tassello di chiusura.



aluminium / pad printing 40 x 9 mm
alluminio / tampografia 40 x 9 mm

Icon

Timeless design.
Design senza tempo.

A perfect synthesis of
past, present and future.

*L'incontro tra passato,
presente e futuro.*



The entire Maxema collection is available in recycled plastic on request /
Tutta la collezione Maxema è realizzabile in plastica riciclata su richiesta

Technical information at p. 237
Informazioni tecniche a pag. 237

IC400 | MATT

Solid colours with matt finish
Colori coprenti con finitura satinata

Essential,
harmonious
design for a style
that is never banal
and always
up-to-date.



01 70 03 18 15 60

79 lime / pad printing 35 x 7 mm
79 lime / tampografia 35 x 7 mm



64 22 04

IC400 | FROST

Transparent colours with matt finish
Colori trasparenti con finitura satinata

Design dal profilo
essenziale e
armonico per uno
stile mai scontato
e sempre attuale.



39 52 53 45

51 violet / screen printing 40 x 30 mm
51 viola / serigrafia 40 x 30 mm



55 49 47

44 blue /
pad printing
35 x 7 mm
44 blu /
tampografia
35 x 7 mm



40

IC400 | MATT AL

Solid colours with matt finish,
aluminium painted finish tip

Colori coprenti con finitura satinata,
punta verniciata in colore alluminio



01 70 03

18 orange /
pad printing 35 x 7 mm
18 arancio /
tampografia 35 x 7 mm



15 74 60 61

71 light violet /
pad printing 35 x 7 mm
71 viola chiaro /
tampografia 35 x 7 mm



25



72 73 79 09 75

27 octan green / pad printing 35 x 7 mm
27 ottanio / tampografia 35 x 7 mm



64 12 22

04 black /
screen printing 40 x 30 mm
04 nero /
serigrafia 40 x 30 mm



Solid colours with glossy finish,
chromed tip

Colori coprenti con finitura lucida,
punta cromata



01 white / pad printing 45 x 9 mm
01 bianco / tampografia 45 x 9 mm



70 03 18 15 74 60

61 magenta / pad printing 35 x 7 mm
61 magenta / tampografia 35 x 7 mm



71 25



72



73 brown / pad printing 35 x 7 mm
73 marrone / tampografia 35 x 7 mm



79 09



27 64 12 22 04

75 dark green / pad printing 35 x 7 mm
75 verde scuro / tampografia 35 x 7 mm

IC400 | FROST AL

Transparent colours, matt finish,
aluminium painted finish tip

*Colori trasparenti con finitura
satinata, punta verniciata in colore
alluminio*

53 orange / pad printing 35 x 7 mm
53 arancio / tampografia 35 x 7 mm
—
screen printing 40 x 30 mm
serigrafia 40 x 30 mm



39

52

45

51

55

49

47

44

40 grey / pad printing 35 x 7 mm
40 grigio / tampografia 35 x 7 mm

IC400 | 30 CR

Transparent colours with
glossy finish, chromed tip

*Colori trasparenti con finitura
lucida, punta cromata*



39

52

53

51

55

49

44

40

45 red /
pad printing 35 x 7 mm
45 rosso /
tampografia 35 x 7 mm

47 aquamarine /
pad printing 35 x 7 mm
47 acquamarina /
tampografia 35 x 7 mm

IC400 | C GOLD

04 black / screen printing 40 x 30 mm
04 nero / serigrafia 40 x 30 mm



01

74

75

22



Solid colours with glossy finish, gilded tip

Colori coprenti con finitura lucida, punta dorata



MY CASE

Universal single pen box in Fedrigoni black card.
Info at p. 246

Astuccio universale per penna singola in cartoncino nero Fedrigoni.
Info pag. 246

IC400 | MET AL

Metallic colours painted finish barrel and cap, aluminium painted finish tip

Fusto e cappuccio verniciati in colori metallizzati, punta verniciata in colore alluminio

Exclusive high strength metallic colours.



92

83 copper / pad printing 35 x 7 mm
83 rame / tampografia 35 x 7 mm



85



94



95



96

Esclusivi colori metallizzati ad alta resistenza.

IC400 | AL CR

Aluminium painted finish barrel and cap, chromed tip

Fusto e cappuccio verniciati in colore alluminio, punta cromata



aluminium / pad printing 35 x 7 mm
alluminio / tampografia 35 x 7 mm

Tag green

Objective: total safety.
Obiettivo: sicurezza totale.

Design that combines
safety and environment
friendliness.

*Il design sposa
la sicurezza e rispetta
l'ambiente.*

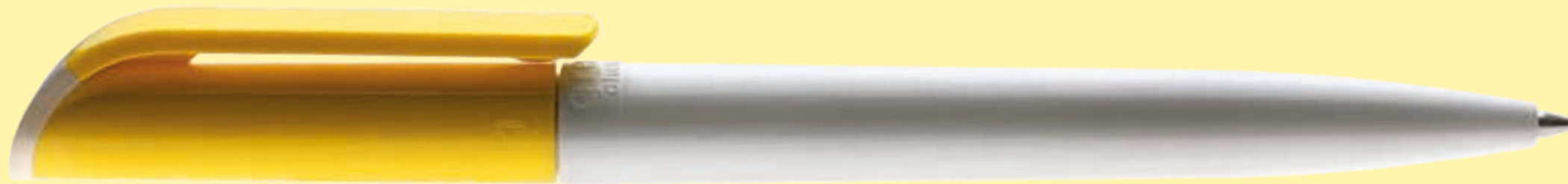

Technical information at p. 238
Informazioni tecniche a pag. 238

Made from a special plastic, suitable for use in toy manufacture.

Realizzata con plastica idonea alla produzione dei giocattoli.



Looking to the future Guarda al futuro

Made of plastic suitable for toy manufacture (according to European standard EN 71-03 and U.S. FDA regulations).

Prodotta con plastica idonea all'utilizzo nei giocattoli (direttiva europea EN 71 - 03 e direttiva americana FDA).



Antibacterial Antibatterica

It is made of antibacterial plastic containing a special additive which releases silver ions that prevent bacteria from colonising the surface of the pen.

La plastica è antibatterica, grazie ad uno speciale additivo che sprigiona ioni d'argento impedendo ai batteri di depositarsi sulle superfici della penna.



Nature friendly Vicina all'ambiente

Made of non-toxic plastics, it has been designed to have a long life and to minimise the risk of harmful substances being released into the environment. Using a pen for as long as possible helps to reduce pollution and enables us to give full expression to the concept of promotion.

Realizzata con materiali atossici, è stata progettata per durare a lungo nel tempo. Una penna che dura di più inquina di meno perchè rimane a lungo nelle nostre mani, massimizzando la diffusione del logo o del messaggio che porta con sé.



Green Chemical

It does not contain dioxin, phthalates, bisphenol A, antimony, arsenic, barium, cadmium, chrome, mercury, lead, polybrominated biphenyls (PBBs), polybrominated diphenyl ethers (PBDEs) or deca-BDE, and conforms to RoHS and REACH directives.

Non contiene: diossina, ftalati, bisfenolo A, antimonio, arsenico, bario, cadmio, cromo, mercurio, piombo, ed è conforme alle normative RoHS e REACH. Bifenili polibromurati (PBB), eteri di difenile (PBDE) e deca BDE sono completamente assenti, ed è conforme alle normative RoHS e REACH.



Really safe Buona davvero

The plastics employed are compliant with European and American FDA food contact regulations.

Le plastiche utilizzate sono conformi alla normativa europea e americana FDA per il contatto alimentare.



CLP compliant Conforme alle regole

It is rated as non hazardous pursuant to the Regulation on Classification, Labelling and Packaging.

La plastica non risulta pericolosa per il CLP (classification, labeling and packaging).



Solid white colour barrel and clip,
solid colours upper plug,
glossy finishes

*Fusto e clip in colore bianco
coprente, tassello superiore in colori
coprenti, finiture lucide*

Green Chemical
plastic releases
silver ions that
have an anti-
bacterial function.



42 43 35 13 29 65 77 54 04

01 white / pad printing 40 x 9 mm
01 bianco / tampografia 40 x 9 mm

Solid white colour barrel and upper
plug, solid colours clip,
glossy finishes

*Fusto e tassello superiore in colore
bianco coprente, clip in colori
coprenti, finiture lucide*

La plastica Green
Chemical sprigiona
ioni d'argento che
svolgono una
funzione antibatterica.



42 43 35 13 65 77 04

29 green / pad printing 40 x 9 mm
29 verde / tampografia 40 x 9 mm

54 blue /
pad printing
40 x 9 mm
54 blu /
tampografia
40 x 9 mm

Icon green

People and environment friendly.
Nel rispetto dell'uomo e della natura.

Testimony of an
enduring message.

*Testimone di un
messaggio destinato
a durare nel tempo.*



Technical information at p. 239
Informazioni tecniche a pag. 239

A significant step forward toward the use of safe plastic.

Un significativo passo avanti nella sicurezza della plastica.



Nature friendly Vicina all'ambiente

Made of non-toxic plastics, it has been designed to have a long life and to minimise the risk of harmful substances being released into the environment. Using a pen for as long as possible helps to reduce pollution and enables us to give full expression to the concept of promotion.

Realizzata con materiali atossici, è stata progettata per durare a lungo nel tempo. Una penna che dura di più inquina di meno perchè rimane a lungo nelle nostre mani, massimizzando la diffusione del logo o del messaggio che porta con sé.



Green Chemical

It does not contain dioxin, phthalates, bisphenol A, antimony, arsenic, barium, cadmium, chrome, mercury, lead, polybrominated biphenyls (PBBs), polybrominated diphenyl ethers (PBDEs) or deca-BDE, and conforms to RoHS and REACH directives.

Non contiene: diossina, ftalati, bisfenolo A, antimonio, arsenico, bario, cadmio, cromo, mercurio, piombo, ed è conforme alle normative RoHS e REACH. Bifenili polibromurati (PBB), eteri di difenile (PBDE) e deca BDE sono completamente assenti, ed è conforme alle normative RoHS e REACH.



Looking to the future Guarda al futuro

Made of plastic suitable for toy manufacture (according to European standard EN 71-03 and U.S. FDA regulations).

Prodotta con plastica idonea all'utilizzo nei giocattoli (direttiva europea EN 71 - 03 e direttiva americana FDA).



Antibacterial Antibatterica

It is made of antibacterial plastic containing a special additive which releases silver ions that prevent bacteria from colonising the surface of the pen.

La plastica è antibatterica, grazie ad uno speciale additivo che sprigiona ioni d'argento impedendo ai batteri di depositarsi sulle superfici della penna.



Really safe Buona davvero

The plastics employed are compliant with European and American FDA food contact regulations.

Le plastiche utilizzate sono conformi alla normativa europea e americana FDA per il contatto alimentare.



CLP compliant Conforme alle regole

It is rated as non hazardous pursuant to the Regulation on Classification, Labelling and Packaging.

La plastica non risulta pericolosa per il CLP (classification, labeling and packaging).

Solid white colour barrel,
solid colours cap, glossy finishes

*Fusto in colore bianco coprente,
cappuccio in colori coprenti,
finiture lucide*

Made of special
plastic used
to manufacture
children's toys.

35 red /
pad printing 35 x 7 mm
35 rosso /
tampografia 35 x 7 mm



42

43



13



65



54



04

29 green / pad printing 35 x 7 mm
29 verde / tampografia 35 x 7 mm

Solid colours with glossy finish

Colori solidi con finitura lucida

Realizzata con
una plastica
speciale idonea
alla produzione
di giocattoli.

01 white / pad printing 35 x 7 mm
01 bianco / tampografia 35 x 7 mm



70



42



43



35



13



29



65 dark green / pad printing 35 x 7 mm
65 verde scuro / tampografia 35 x 7 mm



54



04

Ethic

Elegance and flexibility.
Eleganza e flessibilità.

Tailored to the
customer's
requirements.

*Costruita a misura
di cliente.*



The entire Maxema collection is available in recycled plastic on request /
Tutta la collezione Maxema è realizzabile in plastica riciclata su richiesta

Technical information at p. 240
Informazioni tecniche a pag. 240

ET900 | MULTICOLOUR

Solid colours with glossy finish, metal chrome finish clip, chromed tip

Colori coprenti con finitura lucida, clip in metallo cromato, punta cromata

Designed to outlast passing fashions, like the message it conveys.

Pensata per durare oltre le mode del momento, come il messaggio che deve trasmettere.

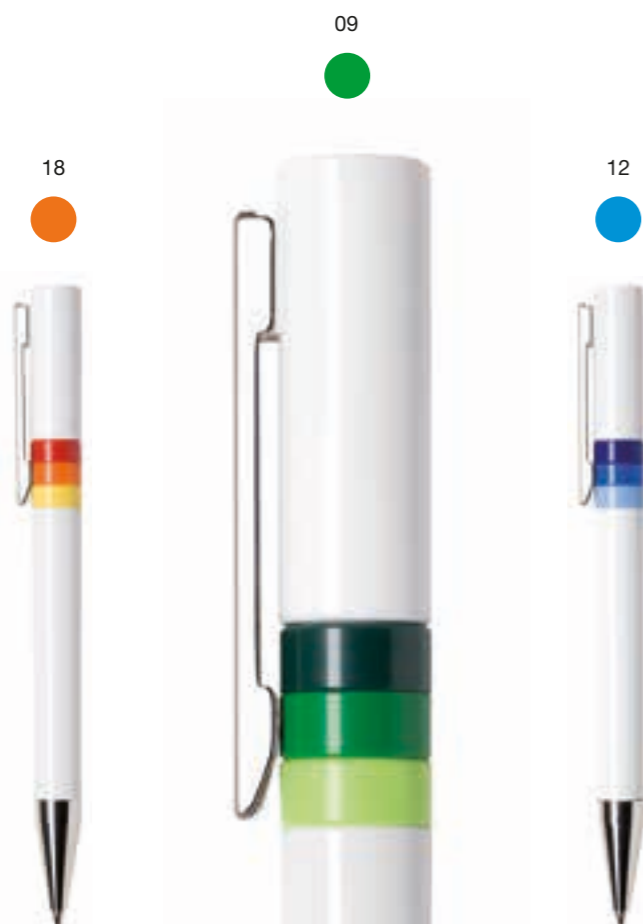

R

B

G green / pad printing 55 x 9,5 mm
G verde / tampografia 55 x 9,5 mm

ET900 | FLAG

Solid colours with glossy finish, metal chrome finish clip, chromed tip

Colori coprenti con finitura lucida, clip in metallo cromato, punta cromata



FR

SP

GE

IT / pad printing 55 x 9,5 mm
IT / tampografia 55 x 9,5 mm

ET900 | C FLAG

Solid colours with glossy finish, metal chrome finish clip, chromed tip

Colori coprenti con finitura lucida, clip in metallo cromato, punta cromata



22 IT

04 IT / pad printing 55 x 9,5 mm
04 IT / tampografia 55 x 9,5 mm

ET900 | B

Solid colours with glossy finish, metal chrome finish clip, chromed tip

Colori coprenti con finitura lucida, clip in metallo cromato, punta cromata



03

18

15

74

25

09

12

22

04

18 orange /
pad printing
55 x 9,5 mm
18 arancio /
tampografia
55 x 9,5 mm

04 black /
pad printing
55 x 9,5 mm
04 nero /
tampografia
55 x 9,5 mm

COENERGIA
group

PENTA BIOMEDICAL®

ET900 | BC

Solid colours with glossy finish, metal chrome finish clip, white top, chromed tip and two rings

Colori coprenti con finitura lucida, clip in metallo cromato, due anelli e punta cromati, tappino bianco



01

70

03

18

15 red / pad printing 30 x 8 mm
15 rosso / tampografia 30 x 8 mm
—
screen printing 45 x 30 mm
serigrafia 45 x 30 mm

aton.eu

74

09

27

12

22

04

ET900 | C CR

Solid colours with glossy finish, metal chrome finish clip, chromed tip, top and two rings

Colori coprenti con finitura lucida, clip in metallo cromato, due anelli, punta e tappino cromati

chrome



01

70



03 yellow /
pad printing
55 x 9,5 mm
03 giallo /
tampografia
55 x 9,5 mm



18

15



74 burgundy /
pad printing
55 x 9,5 mm
74 bordeaux /
tampografia
55 x 9,5 mm



25

09

75

27

chrome



12

22

04

01 white /
screen printing
45 x 30 mm
01 bianco /
serigrafia
45 x 30 mm

ET900 | C GOLD

Solid colours with glossy finish, gilded metal finish clip, gilded tip, top and two rings

Colori coprenti con finitura lucida, clip in metallo dorato, due anelli, punta e tappino dorati

The chrome or gilded details enhance the pen's elegance.

gold



74

27

22

04



I dettagli, cromati o dorati, ne esaltano l'eleganza.

ET900 | AL

Aluminium painted finish barrel, cap and central ring, solid colour two rings and top with glossy finish, metal chrome finish clip, chromed tip

Fusto, cappuccio e anello centrale verniciati in colore alluminio, due anelli e tappino in colore coprente con finitura lucida, clip in metallo cromato, punta cromata



03 18 15 74

09 green / pad printing 55 x 9,5 mm
09 verde / tampografia 55 x 9,5 mm

Refined,
flexible design
for the most
demanding
brands.

ET900 | AL CR

Aluminium painted finish barrel, cap and central ring, metal chrome finish clip, chromed tip, top, and two rings

Fusto, cappuccio e anello centrale verniciati in colore alluminio, clip in metallo cromato, due anelli, tappino e punta cromati



chrome

Design raffinato
e flessibile,
per i brand
più esigenti.

ET900 | AL FLAG

Aluminium painted finish barrel and cap, solid colour rings with glossy finish, metal chrome finish clip, chromed tip

Fusto e cappuccio verniciati in colore alluminio, anelli e tappino in colori coprenti con finitura lucida, clip in metallo cromato, punta cromata



09

IT

ET900 | MET CR

Metallic colours painted finish barrel, cap and central ring, metal chrome finish clip, chromed tip, top and two rings

Fusto, cappuccio e anello centrale verniciati in colori metallizzati, clip in metallo cromato, due anelli, tappino e punta cromati

chrome



91 92 93

85 red /
pad printing
55 x 9,5 mm
85 rosso /
tampografia
55 x 9,5 mm



81 82 89 94

95 blue / pad printing 55 x 9,5 mm
95 blu / tampografia 55 x 9,5 mm



96

96 anthracite / pad printing 30 x 8 mm
96 antracite / tampografia 30 x 8 mm

ET900 | MET AL

Metallic colours painted finish barrel, cap and central ring, metal aluminium painted finish clip, aluminium painted finish tip, top and two rings

Fusto, cappuccio e anello centrale verniciati in colori metallizzati, clip in metallo verniciato in colore alluminio, due anelli, tappino e punta verniciati in colore alluminio

al



92 83 85 89 94 95

91 pearl / pad printing 30 x 8 mm
91 perla / tampografia 30 x 8 mm



Next

The shape for the future
La forma che verrà

Sleek, dynamic lines,
able to boost the
visibility and identity
of every brand.

*Scattante e dinamica:
l'accelerazione positiva
per ogni brand.*



The entire Maxema collection is available in recycled plastic on request /
Tutta la collezione Maxema è realizzabile in plastica riciclata su richiesta

Technical information at p. 241
Informazioni tecniche a pag. 241

NX400 | C CR

Solid colours with glossy finish,
chromed tip

*Colori coprenti con finitura lucida,
punta cromata*

NX400 | 30 CR

Transparent colours with glossy
finish, chromed tip

*Colori trasparenti con finitura lucida,
punta cromata*

01 white / pad printing 50 x 10 mm
01 bianco / tampografia 50 x 10 mm



70 03 18 15 74 09 12 22

04 black / pad printing 50 x 10 mm
04 nero / tampografia 50 x 10 mm



39 52 53 45 55 49 44 40

51 violet /
pad printing
35 x 9 mm
51 viola /
tampografia
35 x 9 mm



47 aquamarine /
pad printing
35 x 9 mm
47 acquamarina /
tampografia
35 x 9 mm



High resolution design.
Il design ad alta definizione.

A synthesis of
contemporary style.

*Sintesi dello stile
contemporaneo.*



The entire Maxema collection is available in recycled plastic on request /
Tutta la collezione Maxema è realizzabile in plastica riciclata su richiesta

Technical information at p. 242
Informazioni tecniche a pag. 242

PX40 | MATT CB

Solid colour barrel with matt finish, solid glossy white colour clip and push-button

Colours with matt finish and white clip: an easy, gritty combination.



01 70 03 18 15 74 60

61 magenta / pad printing 30 x 8 mm
61 magenta / tampografia 30 x 8 mm



71 25 73



79 09 75 26 27 64 77 12 22

05 grey / pad printing 30 x 8 mm
05 grigio / tampografia 30 x 8 mm

Fusto in colore coprente con finitura satinata, clip e tappino in colore bianco coprente lucido

Colori con finitura matt e clip bianca: una combinazione facile e grintosa.



04

Solid colour barrel with matt finish, solid glossy colour clip, chromed push-button

Fusto in colore coprente con finitura satinata, clip in colore coprente lucido, tappino cromato



01 70

03 yellow / pad printing 30 x 8 mm
03 giallo / tampografia 30 x 8 mm



18 15 74 60 61 71 25

73 brown / pad printing 30 x 8 mm
73 marrone / tampografia 30 x 8 mm



79 09 75

26 aquamarine / pad printing 30 x 8 mm
26 acquamarina / tampografia 30 x 8 mm



27



77 12 22 05 04

64 pastel blue / pad printing 60 x 9 mm
64 azzurro pastello / tampografia 60 x 9 mm

PX40 | B

Solid white colour barrel and push-button, solid colours clip, glossy finishes

Fusto e tappino in colore bianco coprente, clip in colori coprenti, finiture lucide



01 03 18 15



74 burgundy / pad printing 30 x 8 mm
74 bordeaux / tampografia 30 x 8 mm



09 12



04

22 blue / pad printing 30 x 8 mm
22 blu / tampografia 30 x 8 mm

PX40 | C

Solid colours with glossy finish
Colori coprenti con finitura lucida



70 03 18 15

09 green / pad printing 30 x 8 mm
09 verde / tampografia 30 x 8 mm



12 22

04 black / pad printing 30 x 8 mm
04 nero / tampografia 30 x 8 mm



PX40 | 30

Transparent colours with glossy finish

Colori trasparenti con finitura lucida



39 52 53 45 51 55 49



47 aquamarine / pad printing
30 x 8 mm 47 ac-
quamarina /
tampografia
30 x 8 mm



44 40

PX40 | FROST NEUTRAL

Transparent colours, matt finish barrel, glossy finish clip and push-button

Colori trasparenti, fusto con finitura satinata, clip e tappino con finitura lucida



53 orange / pad printing
30 x 8 mm
53 arancio /
tampografia
30 x 8 mm



45 51

55 dark violet / pad printing
30 x 8 mm
55 viola scuro /
tampografia
30 x 8 mm

The ventilated push-button is compliant with EU laws for small components.



49 47 44 40

Il tappino ventilato è conforme alle normative CEE sui piccoli componenti.

PX40 | FROST

Transparent colours, matt finish barrel, glossy finish clip and push-button

Colori trasparenti, fusto con finitura satinata, clip e tappino con finitura lucida



39 52 53 45 59

41 magenta / pad printing 30 x 8 mm
41 magenta / tampografia 30 x 8 mm



51



31 lilac / pad printing 30 x 8 mm
31 lilla / tampografia 30 x 8 mm



55



37



38



78 lime / pad printing 30 x 8 mm
78 lime / tampografia 30 x 8 mm



49



34



67



44



40



50

PX40 | GOM C CR

Solid colour barrel with rubber finish, solid colour clip with glossy finish, chromed push-button

Fusto in colore coprente gommato, clip in colore coprente con finitura lucida, tappino cromato



15 red / pad printing 30 x 8 mm
15 rosso / tampografia 30 x 8 mm

74 61 25 79 09 22

04 black / pad printing 30 x 8 mm
04 nero / tampografia 30 x 8 mm

PX40 | GOM 30 CR

Solid colour barrel with rubber finish, transparent colour clip with glossy finish, chromed push-button

Fusto in colore coprente gommato, clip in colore trasparente con finitura lucida, tappino cromato



47 aquamarine / pad printing 30 x 8 mm
47 acquamarina / tampografia 30 x 8 mm

53 45

41 magenta / pad printing 30 x 8 mm
41 magenta / tampografia 30 x 8 mm

55 49

44 50

Bay

Casual and attractive
Disinvolta e accattivante

Draws attention
for its simplicity.

*Attrae per la
sua semplicità.*



The entire Maxema collection is available in recycled plastic on request /
Tutta la collezione Maxema è realizzabile in plastica riciclata su richiesta

Technical information at p. 243
Informazioni tecniche a pag. 243

B500 | MATT BC

Solid white colour barrel,
solid colours cap, matt finishes



70 03 18 15 74

61 71 25 73 79

60 pink / pad printing 30 x 7 mm
60 rosa / tampografia 30 x 7 mm

Fusto in colore bianco coprente,
cappuccio in colori coprenti,
finiture satinare



75 dark green / pad printing 30 x 7 mm
75 verde scuro / tampografia 30 x 7 mm
—
pad printing 60 x 7 mm
tampografia 60 x 7 mm

09 26 27 64 77 12 22 05

04 black / pad printing 60 x 7 mm
04 nero / tampografia 60 x 7 mm

Solid colours with matt finish

Effetto satinato:
raffinata
delicatezza
in 22 colori.

Colori coprenti con finitura satinata

Delicately refined
matt finish in 22
colours.

01 white / pad printing 30 x 7 mm
01 bianco / tampografia 30 x 7 mm



70 03 18 15 74 60 61 71 25

73 brown / pad printing 60 x 7 mm
73 marrone / tampografia 60 x 7 mm



79 09 75 26

27 octan green / pad printing 30 x 7 mm
27 ottanio / tampografia 30 x 7 mm



64 77 12 22 05 04

B500 | BC

Solid white colour barrel,
solid colours cap, glossy finishes

*Fusto in colore bianco coprente,
cappuccio in colori coprenti,
finiture lucide*

B500 | C

Solid colours with glossy finish

Colori coprenti con finitura lucida



03 18 15 25 09 12



22 blue / pad printing 60 x 7 mm
22 blu / tampografia 60 x 7 mm



04



01 70 03 18 15 74 09 12 22

04 black / pad printing 30 x 7 mm
04 nero / tampografia 30 x 7 mm



Transparent colours with glossy finish

Colori trasparenti con finitura lucida



39 52 53



45 red /
pad printing
30 x 7 mm
45 rosso /
tampografia
30 x 7 mm



51 55 49



47 aquamarine /
pad printing
30 x 7 mm
47 acquamarina /
tampografia
30 x 7 mm



44 40

Transparent colours with matt finish

Colori trasparenti con finitura satinata

55 dark violet / pad printing 30 x 7 mm
55 viola scuro / tampografia 30 x 7 mm



39 neutral / pad printing 60 x 7 mm
39 neutro / tampografia 60 x 7 mm



52 53 45 51



49 44 40

Mood Metal



Components / Componenti

- Ⓐ Push-button / tappino
- Ⓑ Clip
- Ⓒ Barrel / fusto
- Ⓓ Tip / punta

Print area / Area stampabile

- ① laser engraving 30 x 7 mm
incisione laser 30 x 7 mm
- ② pad printing / tampografia
40 x 9 mm

Features / Caratteristiche

retractable with return spring /
meccanismo a scatto, con molla
di ritorno

metal push-button, barrel and tip,
individually processed with diamond
mirror face finish / tappino, fusto e
punta in metallo, lavorati singolarmente
con finitura a specchio diamantata

clip made of non-toxic, highly resistant
ABS plastic / clip realizzata in plastica
ABS atossica e ad alta resistenza

“Parker type” refill, blue and black ink /
refill “tipo Parker”, inchiostro blu e nero

You can combine differently coloured parts from
the same version (or code number), or elements
from different versions. / È possibile combinare
particolari di colori diversi della stessa versione
(o codice), oppure abbinare elementi di versioni
differenti.



The entire Maxema collection is available
in recycled plastic on request /
Tutta la collezione Maxema è realizzabile
in plastica riciclata su richiesta

Fast Dry Gel blue and black ink available
on request /
Refill Gel Fast Dry blu e nero disponibile
su richiesta

Mood

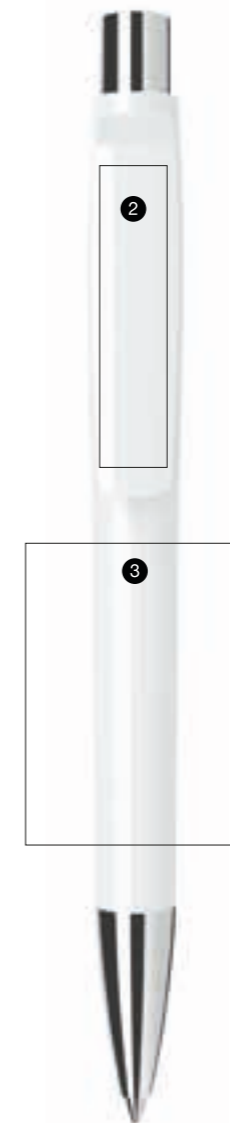
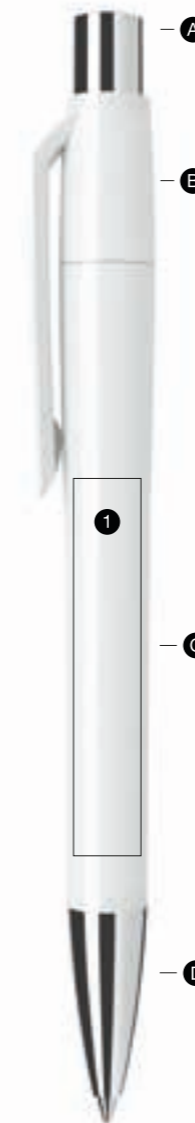

Components / Componenti

- Ⓐ Push-button / tappino
- Ⓑ Clip
- Ⓒ Barrel / fusto
- Ⓓ Tip / punta

Print area / Area stampabile

- ① pad printing / tampografia
46 x 9 mm
- ② pad printing / tampografia
40 x 9 mm
- ③ screen printing / serigrafia
40 x 30 mm

Features / Caratteristiche

retractable with return spring /
meccanismo a scatto, con molla
di ritorno

made of non-toxic, highly resistant
ABS plastic / realizzata in plastica ABS
atossica e ad alta resistenza

metal tip and push-button,
individually processed with diamond
mirror face finish / tappino e punta in
metallo, lavorati singolarmente con
finitura a specchio diamantata

“Parker type” refill, blue and black ink /
refill “tipo Parker”, inchiostro blu e nero

available in glossy or rubberised finish /
disponibile con superfici lucide
o gommate

rubberised barrel versions are only
printable on the clip / le versioni con
fusto gommato sono stampabili solo
su clip



The entire Maxema collection is available
in recycled plastic on request /
Tutta la collezione Maxema è realizzabile
in plastica riciclata su richiesta

Fast Dry Gel blue and black ink available
on request /
Refill Gel Fast Dry blu e nero disponibile
su richiesta

You can combine differently coloured parts from
the same version (or code number), or elements
from different versions. / È possibile combinare
particolari di colori diversi della stessa versione
(o codice), oppure abbinare elementi di versioni
differenti.

Icon Pure

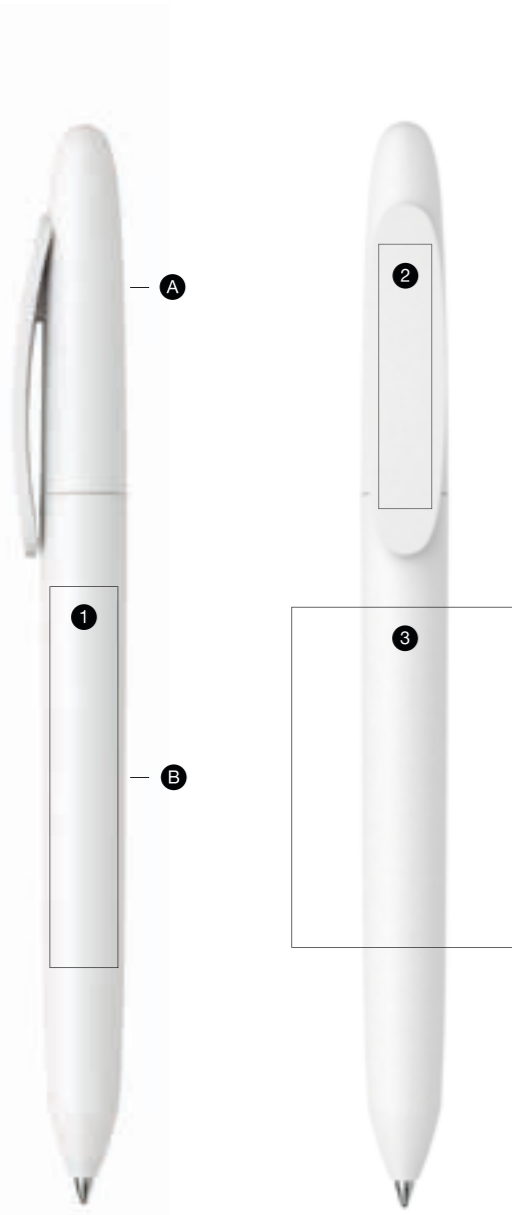

Components / Componenti

- A Cap / cappuccio
- B Barrel / fusto

Print area / Area stampabile

- 1 pad printing / tampografia
50 x 9 mm
- 2 pad printing / tampografia
35 x 7 mm
- 3 screen printing / serigrafia
45 x 30 mm

Features / Caratteristiche

twist-action / meccanismo a rotazione

made of non-toxic highly resistant ABS plastic / realizzata in plastica ABS, atossica e ad alta resistenza

Jumbo refill, blue and black ink / refill Jumbo, inchiostro blu e nero

available in rubberised and matt recycled finish / disponibile con superfici gommate e satinare riciclate

printing must be carried out before rubber coating or, alternatively, using specific inks for rubberised surfaces / la stampa deve essere eseguita prima della gommatura o, in alternativa, con inchiostri specifici per superfici gommate

 IC8 – RECYCLED PLASTIC
PLASTICA RICICLATA

Small imperfections and slight colour variations are to be considered intrinsic features of the recycled material deriving from the post-consumer sector. / Piccole imperfezioni e lievi variazioni cromatiche sono da considerarsi caratteristiche intrinseche del materiale riciclato derivante dal post-consumo.

You can combine differently coloured parts from the same version (or code number), or elements from different versions. / È possibile combinare particolari di colori diversi della stessa versione (o codice), oppure abbinare elementi di versioni differenti.



The entire Maxema collection is available in recycled plastic on request / Tutta la collezione Maxema è realizzabile in plastica riciclata su richiesta

Fast Dry Gel blue and black ink available on request / Refill Gel Fast Dry blu e nero disponibile su richiesta

Flow Pure

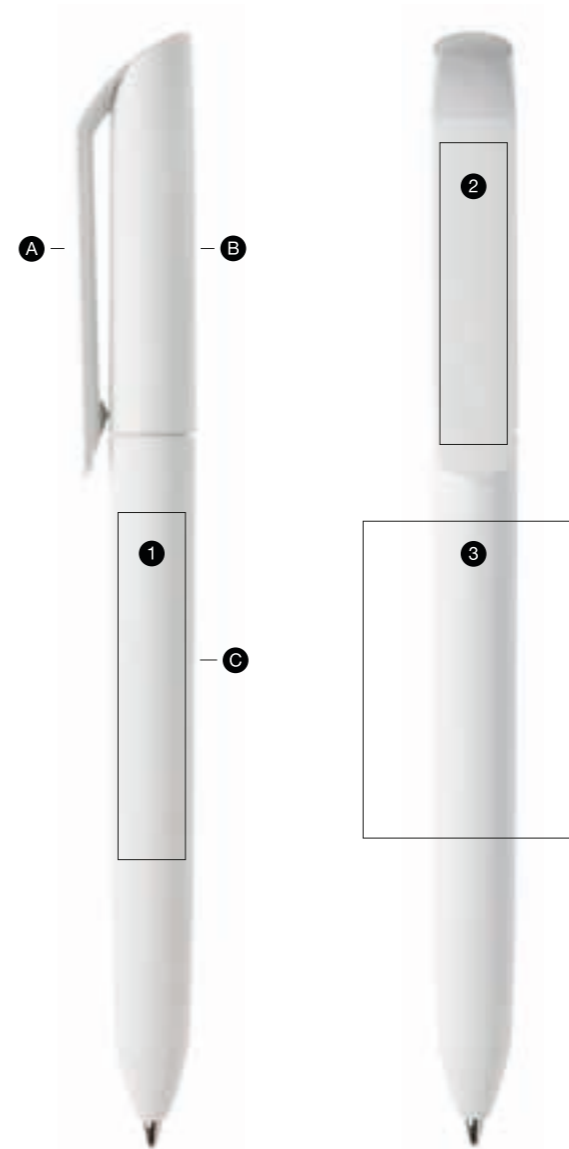

Components / Componenti

- A Clip
- B Cap / cappuccio
- C Barrel / fusto

Print area / Area stampabile

- 1 pad printing / tampografia
50 x 9 mm
- 2 pad printing / tampografia
40 x 9 mm
- 3 screen printing / serigrafia
45 x 30 mm

Features / Caratteristiche

twist-action / meccanismo a rotazione

made of non-toxic highly resistant ABS plastic / realizzata in plastica ABS, atossica e ad alta resistenza

Jumbo refill, blue and black ink / refill Jumbo, inchiostro blu e nero

available in glossy, matt or rubberised finish / disponibile con superfici lucide, satinare o gommate

 F2 P – RECYCLED PLASTIC
PLASTICA RICICLATA

Small imperfections and slight colour variations are to be considered intrinsic features of the recycled material deriving from the post-consumer sector. / Piccole imperfezioni e lievi variazioni cromatiche sono da considerarsi caratteristiche intrinseche del materiale riciclato derivante dal post-consumo.

You can combine differently coloured parts from the same version (or code number), or elements from different versions. / È possibile combinare particolari di colori diversi della stessa versione (o codice), oppure abbinare elementi di versioni differenti.



The entire Maxema collection is available in recycled plastic on request / Tutta la collezione Maxema è realizzabile in plastica riciclata su richiesta

Fast Dry Gel blue and black ink available on request / Refill Gel Fast Dry blu e nero disponibile su richiesta

Flow

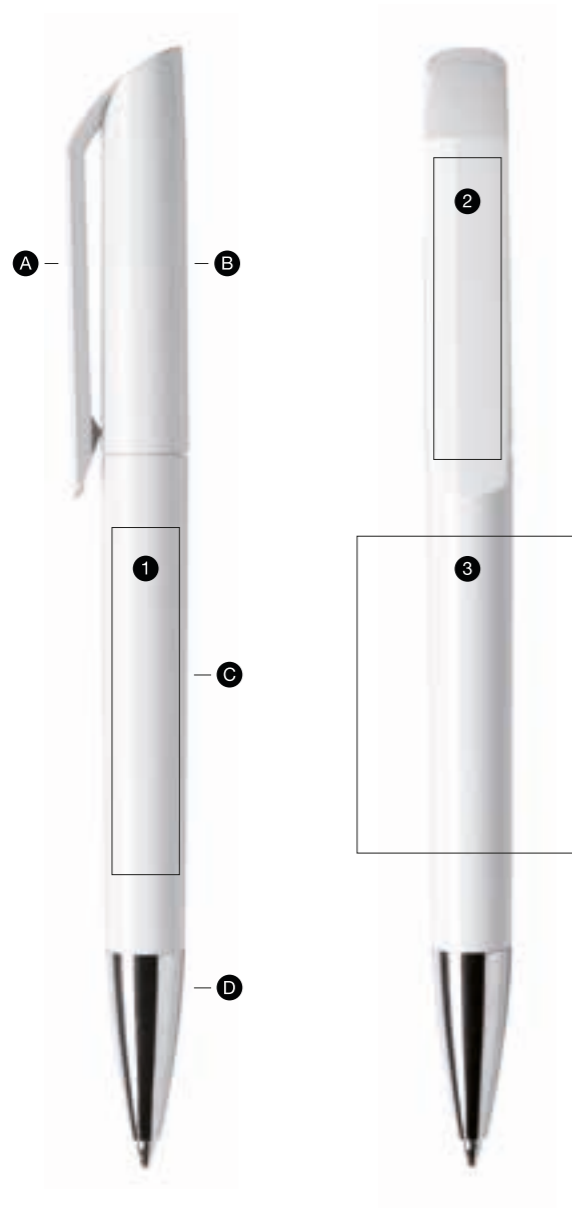

Components / Componenti

- A Clip
- B Cap / cappuccio
- C Barrel / fusto
- D Tip / punta

Print area / Area stampabile

- 1 pad printing / tampografia
46 x 9 mm
- 2 pad printing / tampografia
40 x 9 mm
- 3 screen printing / serigrafia
42 x 30 mm

Features / Caratteristiche

twist-action / meccanismo a rotazione

made of non-toxic highly resistant ABS plastic / realizzata in plastica ABS, atossica e ad alta resistenza

galvanic process used to chrome tip / la cromatura della punta è ottenuta con trattamento galvanico

Jumbo refill, blue and black ink / refill Jumbo, inchiostro blu e nero

available in glossy, matt or rubberised finish / disponibile con superfici lucide, satinare o gommate

in the Texture version, the entire matt cap features a honeycomb design / nella versione Texture il cappuccio satinato è percorso interamente da una trama a nido d'ape

You can combine differently coloured parts from the same version (or code number), or elements from different versions. / È possibile combinare particolari di colori diversi della stessa versione (o codice), oppure abbinare elementi di versioni differenti.



The entire Maxema collection is available in recycled plastic on request / Tutta la collezione Maxema è realizzabile in plastica riciclata su richiesta

Fast Dry Gel blue and black ink available on request / Refill Gel Fast Dry blu e nero disponibile su richiesta

Dot

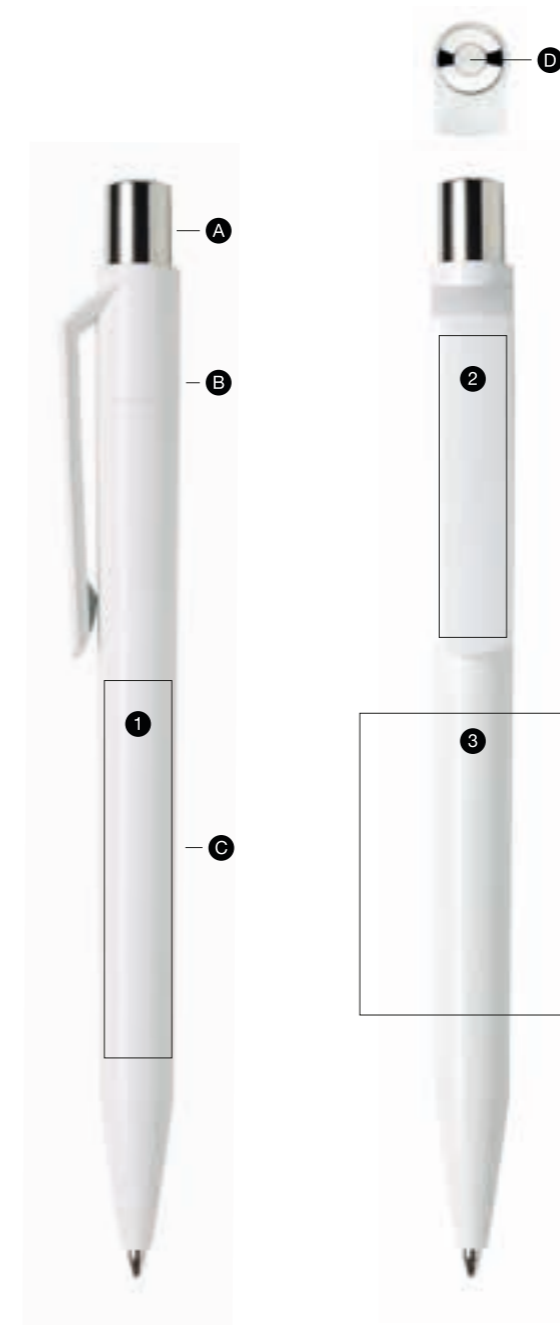

Components / Componenti

- A Push-button / tappino
- B Clip
- C Barrel / fusto
- D Little sphere / piccola sfera

Print area / Area stampabile

- 1 pad printing / tampografia
50 x 9 mm
- 2 pad printing / tampografia
40 x 9 mm
- 3 screen printing / serigrafia
40 x 30 mm

Features / Caratteristiche

retractable with return spring / meccanismo a scatto, con molla di ritorno

made of non-toxic, highly resistant ABS plastic / realizzata in plastica ABS atossica e ad alta resistenza

galvanic process used to chrome and gild ABS push-button / la cromatura e la doratura del tappino sono ottenute con trattamento galvanico

Jumbo refill, blue and black ink / refill Jumbo, inchiostro blu e nero

available in glossy, matt or rubberised finish / disponibile con superfici lucide, satinare o gommate

rubberised barrel versions are only printable on the clip / le versioni con fusto gommato sono stampabili solo su clip

D1 – RECYCLED PLASTIC
PLASTICA RICICLATA

Small imperfections and slight colour variations are to be considered intrinsic features of the recycled material deriving from the post-consumer sector. / Piccole imperfezioni e lievi variazioni cromatiche sono da considerarsi caratteristiche intrinseche del materiale riciclato derivante dal post-consumo.

You can combine differently coloured parts from the same version (or code number), or elements from different versions. / È possibile combinare particolari di colori diversi della stessa versione (o codice), oppure abbinare elementi di versioni differenti.



The entire Maxema collection is available in recycled plastic on request / Tutta la collezione Maxema è realizzabile in plastica riciclata su richiesta

Fast Dry Gel blue and black ink available on request / Refill Gel Fast Dry blu e nero disponibile su richiesta

Zink

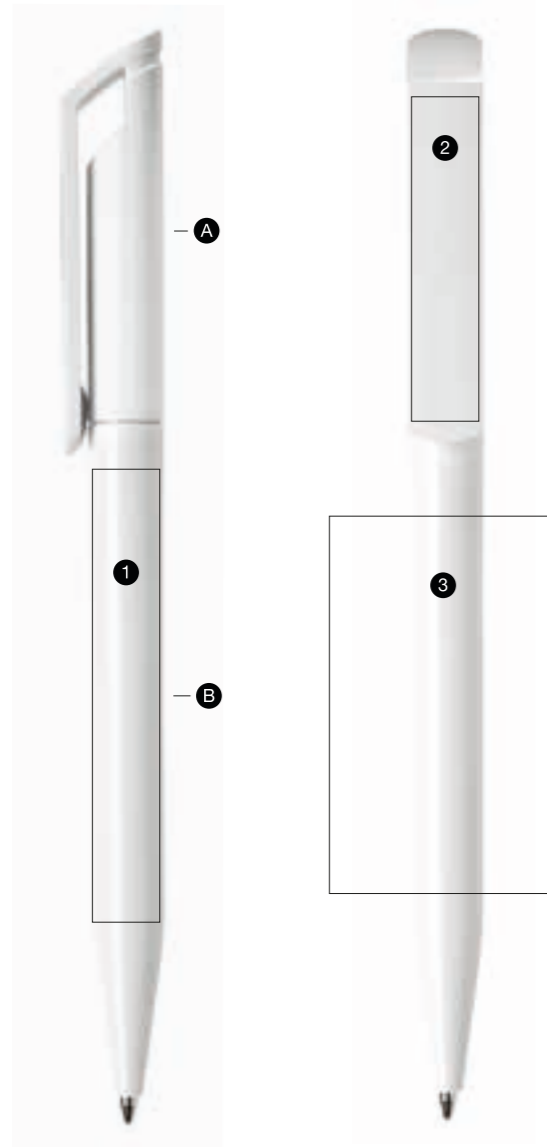

Components / Componenti

- A** Cap / cappuccio
- B** Barrel / fusto

Print area / Area stampabile

- 1** pad printing / tampografia 60 x 9 mm
- 2** pad printing / tampografia 43 x 9 mm
- 3** screen printing / serigrafia 50 x 30 mm

Features / Caratteristiche

twist-action / meccanismo a rotazione

made of non-toxic, highly resistant ABS plastic / realizzata in plastica ABS atossica e ad alta resistenza

Jumbo refill, blue and black ink / refill Jumbo, inchiostro blu e nero

available in glossy finish / disponibile con superfici lucide

 Z1 — RECYCLED PLASTIC
PLASTICA RICICLATA

Small imperfections and slight colour variations are to be considered intrinsic features of the recycled material deriving from the post-consumer sector. / Piccole imperfezioni e lievi variazioni cromatiche sono da considerarsi caratteristiche intrinseche del materiale riciclato derivante dal post-consumo.

You can combine differently coloured parts from the same version (or code number), or elements from different versions. / È possibile combinare particolari di colori diversi della stessa versione (o codice), oppure abbinare elementi di versioni differenti.



The entire Maxema collection is available in recycled plastic on request / Tutta la collezione Maxema è realizzabile in plastica riciclata su richiesta

Fast Dry Gel blue and black ink available on request / Refill Gel Fast Dry blu e nero disponibile su richiesta

View



Components / Componenti

- A** Clip
- B** Cap / cappuccio
- C** Barrel / fusto

Print area / Area stampabile

- 1** pad printing / tampografia 40 x 6 mm
- 2** laser engraving 30 x 7 mm
incisione laser 30 x 7 mm
- 3** pad printing / tampografia 47 x 9 mm
- 4** screen printing / serigrafia 42 x 30 mm

Features / Caratteristiche

twist-action / meccanismo a rotazione

made of non-toxic, highly resistant ABS plastic / realizzata in plastica ABS atossica e ad alta resistenza

metal chrome finish clip available for laser engraving and pad printing / clip in metallo cromato, disponibile per incisione laser e tampografia

galvanic process used to chrome tip / la cromatura della punta è ottenuta con trattamento galvanico

Jumbo refill, blue and black ink / refill Jumbo, inchiostro blu e nero

available in glossy, rubberised or aluminium painted finish / disponibile con superfici lucide, gommate o verniciate in colore alluminio



The entire Maxema collection is available in recycled plastic on request / Tutta la collezione Maxema è realizzabile in plastica riciclata su richiesta

Fast Dry Gel blue and black ink available on request / Refill Gel Fast Dry blu e nero disponibile su richiesta

You can combine differently coloured parts from the same version (or code number), or elements from different versions. / È possibile combinare particolari di colori diversi della stessa versione (o codice), oppure abbinare elementi di versioni differenti.

Tag

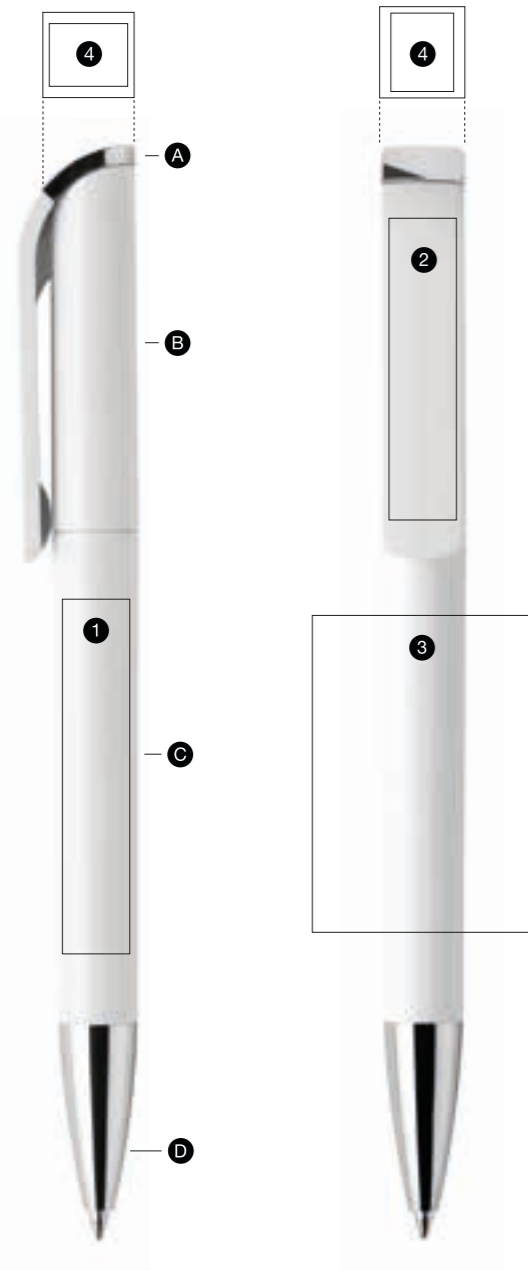

Components / Componenti

- A Plug / tassello
- B Clip / clip
- C Barrel / fusto
- D Tip / punta

Print area / Area stampabile

- 1 pad printing / tampografia
47 x 9 mm
- 2 pad printing / tampografia
40 x 9 mm
- 3 screen printing / serigrafia
42 x 30 mm
- 4 pad printing / tampografia
8 x 10 mm

Features / Caratteristiche

twist-action / meccanismo a rotazione

made of non-toxic, highly resistant
ABS plastic / realizzata in plastica ABS
atossica e ad alta resistenza

galvanic process used to chrome tip
and upper plug / la cromatura della
punta e del tassello superiore
è ottenuta con trattamento galvanico

Jumbo refill, blue and black ink /
refill Jumbo, inchiostro blu e nero

available in glossy, matt and metallic
or aluminium painted finish /
disponibile con superfici lucide,
satinare o verniciate con colori
metallizzati o alluminio

You can combine differently coloured parts from
the same version (or code number), or elements
from different versions. / È possibile combinare
particolari di colori diversi della stessa versione
(o codice), oppure abbinare elementi di versioni
differenti.



The entire Maxema collection is available
in recycled plastic on request /
Tutta la collezione Maxema è realizzabile
in plastica riciclata su richiesta

Fast Dry Gel blue and black ink available
on request /
Refill Gel Fast Dry blu e nero disponibile
su richiesta

Icon

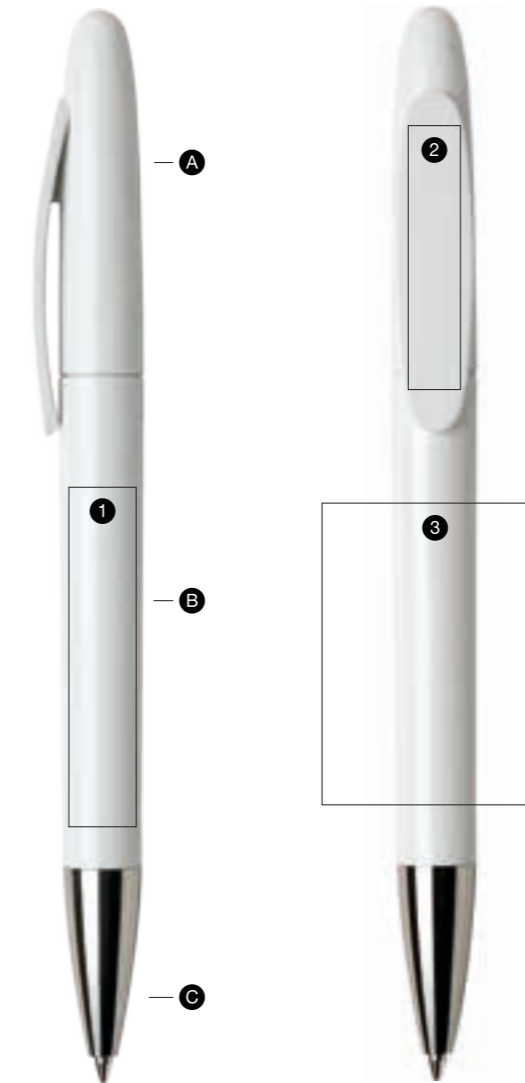

Components / Componenti

- A Cap / cappuccio
- B Barrel / fusto
- C Tip / punta

Print area / Area stampabile

- 1 pad printing / tampografia
45 x 9 mm
- 2 pad printing / tampografia
35 x 7 mm
- 3 screen printing / serigrafia
40 x 30 mm

Features / Caratteristiche

twist-action / meccanismo a rotazione

made of non-toxic, highly resistant
ABS plastic / realizzata in plastica ABS,
atossica e ad alta resistenza

galvanic process used to chrome and
gild ABS tip / la cromatura e la doratura
della punta in ABS sono ottenute
con trattamento galvanico

Jumbo refill, blue and black ink / refill
Jumbo, inchiostro blu e nero

available in glossy, matt and metallic
or aluminium painted finish / disponibile
con superfici lucide, satinare
o verniciate in colori metallizzati
o alluminio

You can combine differently coloured parts from
the same version (or code number), or elements
from different versions. / È possibile combinare
particolari di colori diversi della stessa versione
(o codice), oppure abbinare elementi di versioni
differenti.



The entire Maxema collection is available
in recycled plastic on request /
Tutta la collezione Maxema è realizzabile
in plastica riciclata su richiesta

Fast Dry Gel blue and black ink available
on request /
Refill Gel Fast Dry blu e nero disponibile
su richiesta

Tag green

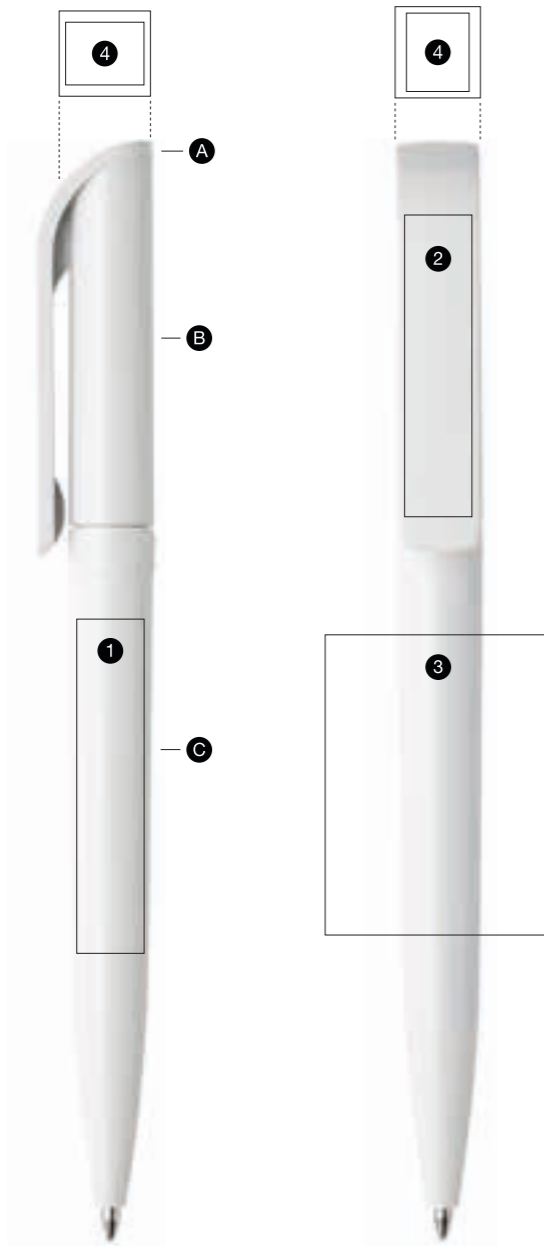

Components / Componenti

- A Plug / tassello
- B Clip / clip
- C Barrel / fusto

Print area / Area stampabile

- 1 pad printing / tampografia
45 x 9 mm
- 2 pad printing / tampografia
40 x 9 mm
- 3 screen printing / serigrafia
40 x 30 mm
- 4 pad printing / tampografia
8 x 10 mm

Features / Caratteristiche

twist-action / meccanismo a rotazione

made of non-toxic, highly resistant special ABS plastic certified for use in toy manufacture / realizzata in plastica ABS speciale, ad alta resistenza, atossica e certificata per l'utilizzo nei giocattoli

antibacterial / antibatterico

X20 refill, blue and black ink / refill X-20, inchiostro blu e nero

available in glossy finish / disponibile con superfici lucide

You can combine differently coloured parts from the same version (or code number), or elements from different versions. / È possibile combinare particolari di colori diversi della stessa versione (o codice), oppure abbinare elementi di versioni differenti.

Icon green

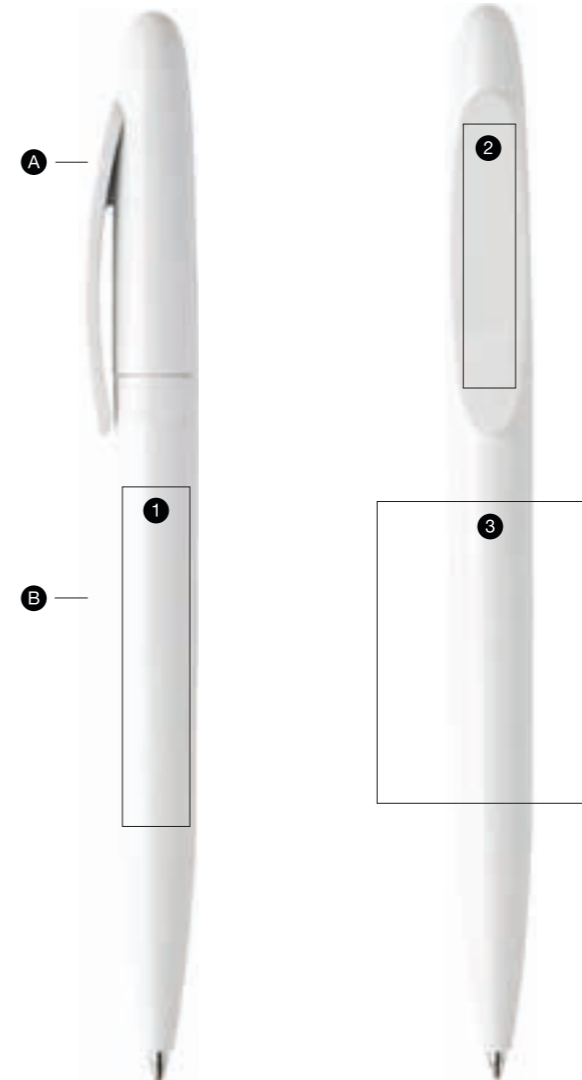

Components / Componenti

- A Cap / cappuccio
- B Barrel / fusto

Print area / Area stampabile

- 1 pad printing / tampografia
45 x 9 mm
- 2 pad printing / tampografia
35 x 7 mm
- 3 screen printing / serigrafia
40 x 30 mm

Features / Caratteristiche

twist-action / meccanismo a rotazione

made of non-toxic, highly resistant special ABS plastic certified for use in toy manufacture / realizzata in plastica ABS speciale, ad alta resistenza, atossica e certificata per l'utilizzo nei giocattoli

antibacterial / antibatterica

X20 refill, blue and black ink / refill X20, inchiostro blu e nero

available in glossy finish / disponibile con superfici lucide

You can combine differently coloured parts from the same version (or code number), or elements from different versions. / È possibile combinare particolari di colori diversi della stessa versione (o codice), oppure abbinare elementi di versioni differenti.

Ethic



Components / Componenti

- A Small cap / tappino
- B Cap / cappuccio
- C Rings / anelli
- D Barrel / fusto
- E Tip / punta

Print area / Area stampabile

- 1 pad printing / tampografia
30 x 8 mm
- 2 screen printing / serigrafia
45 x 30 mm
- 3 pad printing / tampografia
55 x 9,5 mm

Features / Caratteristiche

twist-action / meccanismo a rotazione

made of non-toxic, highly resistant
ABS plastic / realizzata in plastica ABS,
atossica e ad alta resistenza

metal clip with chrome, gilded
or aluminium painted finish / clip in
metallo, con finitura cromata,
dorata o verniciata color alluminio

galvanic process used to chrome
or to gild ABS parts / la cromatura e
la doratura delle parti in ABS sono
ottenute con trattamento galvanico

Jumbo refill, blue and black ink / refill
Jumbo, inchiostro blu e nero

available in glossy and metallic
or aluminium painted finish/ disponibile
con superfici lucide o verniciate in
colori metallizzati o alluminio

You can combine differently coloured parts from
the same version (or code number), or elements
from different versions. / È possibile combinare
particolari di colori diversi della stessa versione
(o codice), oppure abbinare elementi di versioni
differenti.



The entire Maxema collection is available
in recycled plastic on request /
Tutta la collezione Maxema è realizzabile
in plastica riciclata su richiesta

Fast Dry Gel blue and black ink available
on request /
Refill Gel Fast Dry blu e nero disponibile
su richiesta

Next

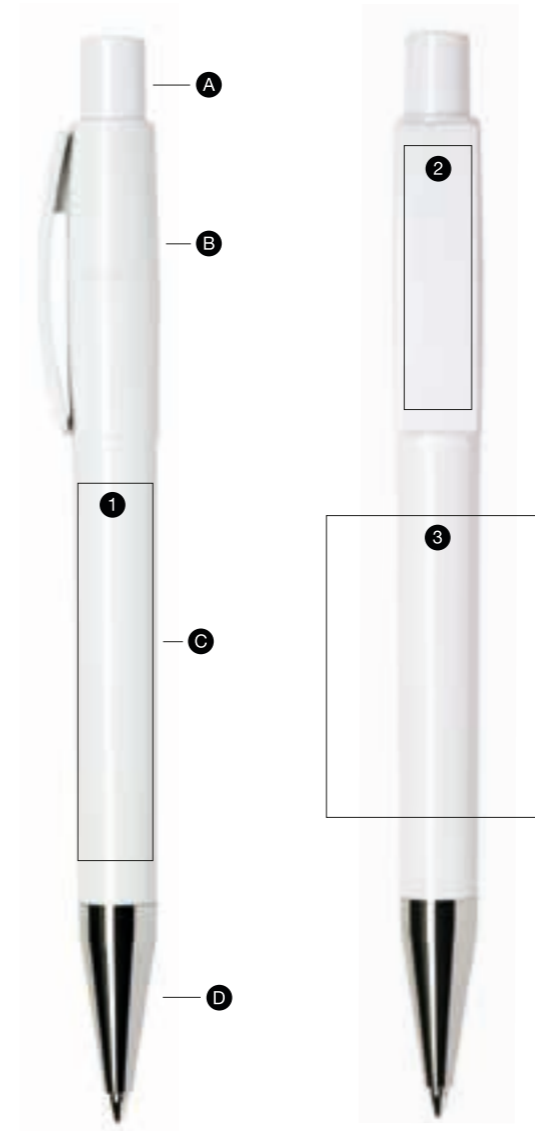

Components / Componenti

- A Push-button / tappino
- B Clip
- C Barrel / fusto
- D Tip / punta

Print area / Area stampabile

- 1 pad printing / tampografia
50 x 10 mm
- 2 pad printing / tampografia
35 x 9 mm
- 3 screen printing / serigrafia
40 x 30 mm

Features / Caratteristiche

retractable with return spring /
meccanismo a scatto, con molla
di ritorno

ventilated push-button
tappino ventilato

made of non-toxic, highly resistant
ABS plastic / realizzata in plastica ABS,
atossica e ad alta resistenza

Jumbo refill, blue and black ink /
refill Jumbo, inchiostro blu e nero

the barrel is available in glossy finish /
il fusto è disponibile con superfici lucide

galvanic process used to chrome
the ABS tip / la cromatura della punta
in ABS è ottenuta con trattamento
galvanico



The entire Maxema collection is available
in recycled plastic on request /
Tutta la collezione Maxema è realizzabile
in plastica riciclata su richiesta

Fast Dry Gel blue and black ink available
on request /
Refill Gel Fast Dry blu e nero disponibile
su richiesta

You can combine differently coloured parts from
the same version (or code number), or elements
from different versions. / È possibile combinare
particolari di colori diversi della stessa versione
(o codice), oppure abbinare elementi di versioni
differenti.

Pixel

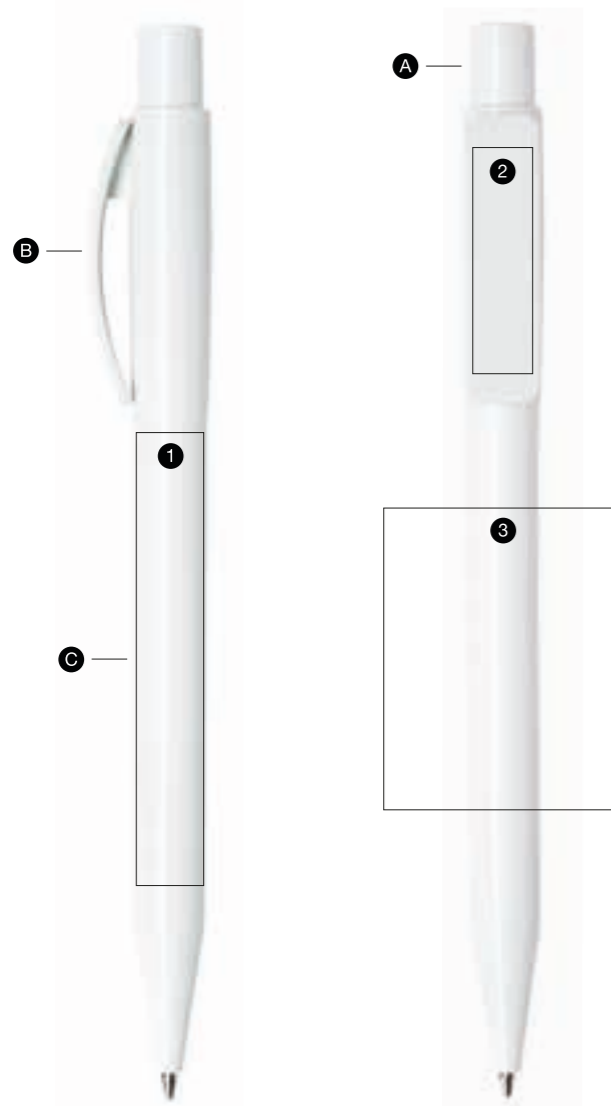

Components / Componenti

- Ⓐ Push-button / tappino
- Ⓑ Clip
- Ⓒ Barrel / fusto

Print area / Area stampabile

- ① pad printing / tampografia
60 x 9 mm
- ② pad printing / tampografia
40 x 31 mm
- ③ screen printing / serigrafia
40 x 30 mm

Features / Caratteristiche

retractable / meccanismo a scatto

ventilated push-button / tappino ventilato

made of non-toxic, highly resistant
ABS plastic / realizzata in plastica ABS,
atossica e ad alta resistenza

X-20 refill, blue and black ink /
refill X 20, inchiostro blu e nero

the barrel is available in glossy, matt
or rubberised finish / il fusto
è disponibile con superfici lucide,
satinato o gommato

galvanic process used to chrome
the ABS push-button / la cromatura
del tappino in ABS è ottenuta con
trattamento galvanico

rubberised barrel versions are only
printable on the clip / le versioni
con fusto gommato sono stampabili
solo su clip

 PX40 – RECYCLED PLASTIC
PLASTICA RICICLATA

Small imperfections and slight colour variations
are to be considered intrinsic features of
the recycled material deriving from the post-
consumer sector. / Piccole imperfezioni e lievi
variazioni cromatiche sono da considerarsi
caratteristiche intrinseche del materiale riciclato
derivante dal post-consumo.

You can combine differently coloured parts from
the same version (or code number), or elements
from different versions. / È possibile combinare
particolari di colori diversi della stessa versione
(o codice), oppure abbinare elementi di versioni
differenti.



The entire Maxema collection is available
in recycled plastic on request /
Tutta la collezione Maxema è realizzabile
in plastica riciclata su richiesta

Fast Dry Gel blue and black ink available
on request /
Refill Gel Fast Dry blu e nero disponibile
su richiesta

Bay

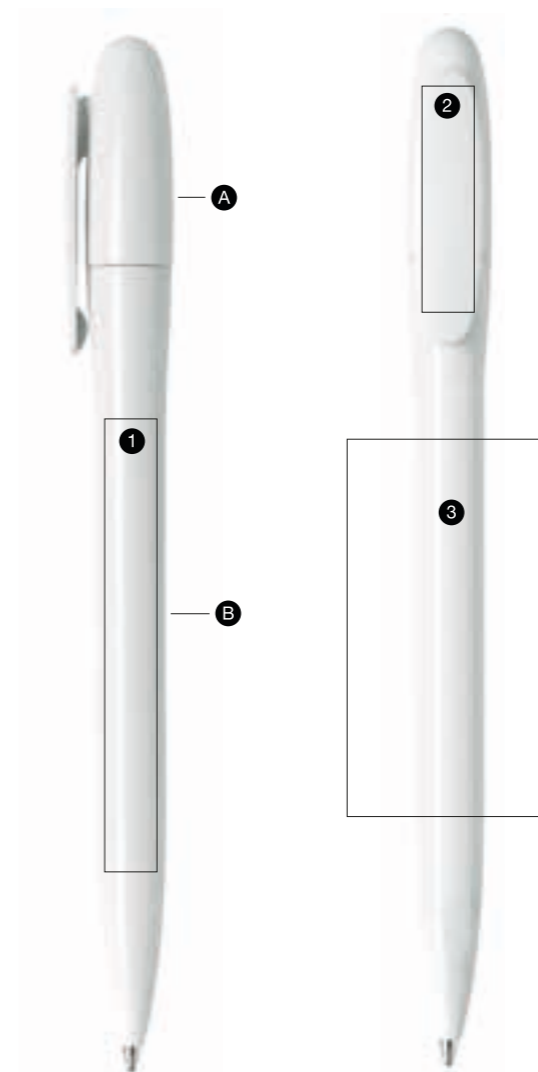

Components / Componenti

- Ⓐ Cap / cappuccio
- Ⓑ Barrel / fusto

Print area / Area stampabile

- ① pad printing / tampografia
60 x 7 mm
- ② pad printing / tampografia
30 x 7 mm
- ③ screen printing / serigrafia
50 x 28 mm

Features / Caratteristiche

twist-action / meccanismo a rotazione

made of non-toxic, highly resistant
ABS plastic / realizzata in plastica ABS,
atossica e ad alta resistenza

X-20 refill, blue and black ink /
refill X-20, inchiostro blu e nero

available in glossy or matt finish /
disponibile con superfici lucide
o satinato

 B500 – RECYCLED PLASTIC
PLASTICA RICICLATA

Small imperfections and slight colour variations
are to be considered intrinsic features of
the recycled material deriving from the post-
consumer sector. / Piccole imperfezioni e lievi
variazioni cromatiche sono da considerarsi
caratteristiche intrinseche del materiale riciclato
derivante dal post-consumo.

You can combine differently coloured parts from
the same version (or code number), or elements
from different versions. / È possibile combinare
particolari di colori diversi della stessa versione
(o codice), oppure abbinare elementi di versioni
differenti.



The entire Maxema collection is available
in recycled plastic on request /
Tutta la collezione Maxema è realizzabile
in plastica riciclata su richiesta

Fast Dry Gel blue and black ink available
on request /
Refill Gel Fast Dry blu e nero disponibile
su richiesta

Packaging

MY CASE



Pad printing / tampografia

- ❶ 4,2 x 16,6 cm
- ❷ 4,3 x 14,8 cm

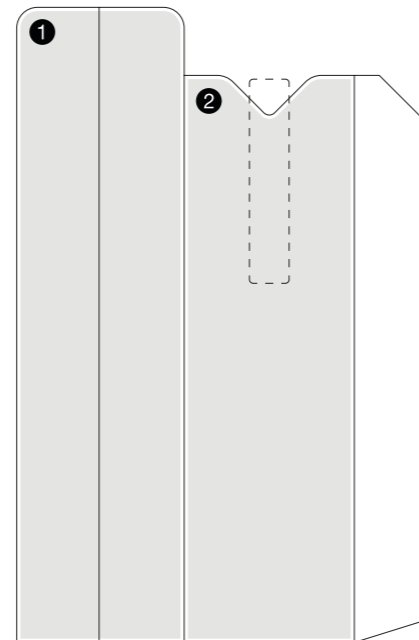

universal single pen case in
Fedrigoni Ultra Black 280 g/m² card,
personalisable with pad printing

size: 4,4 x 16,8 cm

—
astuccio universale per penna singola
in cartoncino Fedrigoni Ultra Black 280
gr/m², personalizzabile con stampa
tampografica

dimensioni: 4,4 x 16,8 cm

MY BOX



Pad printing / tampografia

- ❶ 14,8 x 2 cm
- ❷ 14,9 x 2 cm
- ❸ 14,8 x 2 cm
- ❹ 14,8 x 2 cm

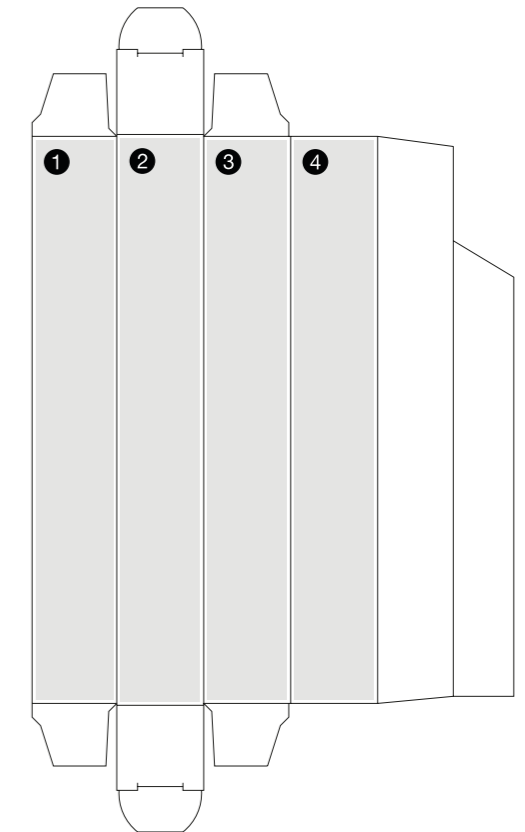

universal reclosable single pen case in
Fedrigoni Ultra Black 280 g/m² card,
personalisable with pad printing

size: 2,3 x 15,1 x 2,3 cm

—
astuccio universale richiudibile per
penna singola in cartoncino Fedrigoni
Ultra Black 280 gr/m², personalizzabile
con stampa tampografica

dimensioni: 2,3 x 15,1 x 2,3 cm

Packaging

MY BOX — RECYCLED

NEW



Una penna in plastica riciclata
si merita un packaging eco-friendly.

**A RECYCLED
PLASTIC PEN
DESERVES
ECO-FRIENDLY
PACKAGING.**

Pad printing / tampografia

- ① 14,8 x 2 cm
- ② 14,9 x 2 cm
- ③ 14,8 x 2 cm
- ④ 14,8 x 2 cm

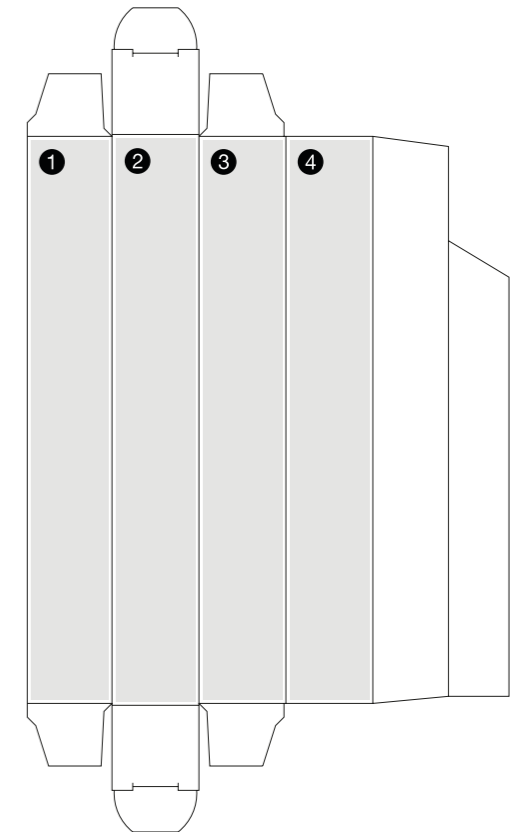

universal reclosable single pen case in Fedrigoni recycled paper Kraft, Clay and Ardesia 250 g/m² card, personalisable with pad printing

size: 2,3 x 15,1 x 2,3 cm

—
astuccio universale richiudibile per penna singola in cartoncino Fedrigoni riciclato Kraft, Clay e Ardesia 250 g/m², personalizzabile con stampa tampografica

dimensioni: 2,3 x 15,1 x 2,3 cm

Minikit

GENERAL / GENERICO

The essential selection of our best sellers: Minikits are valuable tools to display, consult and collect.

La selezione essenziale dei nostri best seller: i Minikit sono strumenti preziosi da esporre, consultare, collezionare.



5 printed pens in assorted colours of the most representative models

size: 14,7 x 19 cm (closed format)

5 penne stampate in colori assortiti dei modelli più rappresentativi

dimensioni: 14,7 x 19 cm (formato chiuso)

MOOD METAL

Metal elegance in 3 different finishes and clip available in 23 shades.

L'eleganza del metallo in 3 diverse finiture e clip disponibile in 23 colorazioni.



3 Mood Metal in chrome, titanium grey and gold finish

size: 10,2 x 19 cm (closed format)

3 Mood Metal nelle finiture: cromato, grigio titanio e oro

dimensioni: 10,2 x 19 cm (formato chiuso)

Minikit

8 RECYCLED PENS



For our recycled plastic pens samples we have chosen sustainable packaging made up of cellulose, certified recycled fibres and cotton fibres. FSC certification guarantees that the entire wood-paper supply chain derives from environmentally friendly, socially useful and economically sustainable forest management.

contains 8 pens of one model, in all available colours

size: 24,3 x 20 cm (closed format)

—
contiene 8 penne di un modello, in tutti i colori disponibili

dimensioni: 24,3 x 20 cm (formato chiuso)

Minikit

6 RECYCLED PENS



Per i campionari delle nostre penne in plastica riciclata abbiamo scelto un packaging sostenibile composto da cellulosa, fibre di riciclo certificate e fibre di cotone. La certificazione FSC garantisce che l'intera filiera legno-carta derivi da una gestione forestale rispettosa dell'ambiente, socialmente utile ed economicamente sostenibile.



contains 6 different recycled plastic models:
Icon Pure, Flow Pure, Dot, Zink, Pixel and Bay

size: 19 x 19,8 cm (closed format)

—
contiene 6 diversi modelli di penne in plastica riciclata:
Icon Pure, Flow Pure, Dot, Zink, Pixel e Bay

dimensioni: 19 x 19,8 cm (formato chiuso)

Kit and box sets / Kit e raccoglitori

KIT



20 printed pens in assorted colours of the most representative models

size: 25 x 34 cm (closed format)

—
20 penne stampate in colori assortiti dei modelli più rappresentativi

dimensioni: 25 x 34 cm (formato chiuso)

BOX SETS / RACCOGLITORI

The Kits are available in 1, 2 or 3 unit box sets / i Kit sono disponibili in raccoglitori da 1, 2 o 3

- ① 28 x 33 x 3 cm
- ② 28 x 33 x 5,5 cm
- ③ 28 x 33 x 8 cm

MODEL KIT / KIT MODELLO

20 printed pens in assorted colours of a single model size: 25 x 34 cm (closed format)

—
20 penne stampate in colori assortiti di un unico modello dimensioni: 25 x 34 cm (formato chiuso)

—
the Model Kit is available for / il Kit Modello è disponibile per:
Mood, Flow Pure, Flow, Dot, Zink, View, Tag, Icon, Icon Green, Icon Pure, Tag Green, Ethic, Pixel, Next, Bay.



On request we can prepare customised sets of samples containing specific versions and colours of pens.

—
Su richiesta possiamo realizzare campionari personalizzati con penne di specifiche versioni e colori.

Inks and refills / *Inchiostri e refill*

INKS / INCHIOSTRI



blue
blu



black
nero

X-20



tungsten carbide ball Ø 1 mm, length 107 mm, for up to 2000 meters of writing
sfera in carburo di tungsteno Ø 1 mm, lunghezza 107 mm, fino a 2000 metri di scrittura

JUMBO



tungsten carbide ball Ø 1 mm, length 107 mm, for up to 2500 meters of writing
sfera in carburo di tungsteno Ø 1 mm, lunghezza 107 mm, fino a 2500 metri di scrittura

RT 90 PARKER TYPE / TIPO PARKER



tungsten carbide ball Ø 0,8 mm, length 98 mm, for up to 4000 meters of writing
sfera in carburo di tungsteno Ø 0,8 mm, lunghezza 98 mm, fino a 4000 metri di scrittura

RT 90 ON DEMAND / SU RICHIESTA



tungsten carbide ball Ø 1 mm, length 98 mm, for up to 4000 meters of writing
sfera in carburo di tungsteno Ø 1 mm, lunghezza 98 mm, fino a 4000 metri di scrittura

GEL FAST DRY ON DEMAND / SU RICHIESTA



titanium carbide ball (SS, TC), Ø 0.7 mm, tip in stainless steel, length 98 mm, up to 700 meters of writing
sfera in carburo di titanio (SS, TC) Ø 0,7 mm, punta in acciaio inox, lunghezza 98 mm, fino a 700 metri di scrittura

The refill's barrel is made of polypropilene, the tip is made of nickel-plated brass.

The non-toxic ink is Dokumental. All Dokumental inks comply with European REACH and American TSCA standards.

—
Il tubetto del refill è in polipropilene, la punta è in ottone nichelato. L'inchiostro, atossico, è Dokumental. Tutti gli inchiostri Dokumental sono conformi alla normativa europea REACH e americana TSCA.

The refill's barrel is made of polypropilene, the tip is made of nickel-silver brass.

The non-toxic ink is Dokumental. All Dokumental inks comply with European REACH and American TSCA standards.

—
Il tubetto del refill è in polipropilene, la punta è in nichel-silver. L'inchiostro, atossico, è Dokumental. Tutti gli inchiostri Dokumental sono conformi alla normativa europea REACH e americana TSCA.

Water-based, non-toxic gel ink, produced in Italy and compliant with European REACH and American TSCA standards. The refill's barrel is made of polypropilene.

—
Inchiostro gel a base acqua, atossico e prodotto in Italia, conforme alla normativa europea REACH e americana TSCA. Il tubetto del refill è in polipropilene.

all rights reserved maxema srl
tutti i diritti riservati maxema srl

The brands mentioned in this catalogue are the exclusive property of the respective owners. They are used for purely illustrative purposes and cannot be the object of any buying and selling transactions, under any circumstances.

I marchi menzionati in questo catalogo sono di proprietà esclusiva dei rispettivi proprietari. L'utilizzo dei suddetti marchi è a puro titolo esemplificativo e non potrà mai, in alcun caso, essere oggetto di trattative commerciali.

art direction and graphic design
undesign.it

still life
infiniostudio.com

editing
elena ambrosio
sara zampedri





Made
in Italy



Prodotto
in Italia



Fabriqué
en Italie



Fabricado
en Italia

Our colour chart is shown below with the Pantone codes closest to those of our Palette. Matches are approximate.

In questa tabella sono riportati i nostri colori con i codici Pantone che più si avvicinano a quelli della nostra Palette. La corrispondenza è puramente indicativa.

solid / coprenti

01	white / bianco	
70	cream / crema	pant 7499
03	yellow / giallo	pant 120
18	orange / arancio	pant 1505
15	red / rosso	pant 187
74	burgundy / bordeaux	pant 195
60	pink / rosa	pant 1905
61	magenta	pant 213
71	light violet / viola chiaro	pant 270
25	dark violet / viola scuro	pant violet
72	leather / cuoio	pant 7571
73	brown / marrone	pant 7582
79	lime	pant 381
09	green / verde	pant 348
75	dark green / verde scuro	pant 3435
26	aquamarine / acquamarina	pant 3262
27	octan green / ottanio	pant 321
64	pastel blue / azzurro pastello	pant 283
77	cyan / ciano	pant 2995
12	light blue / azzurro	pant 285
22	blue / blu	pant 287
05	grey / grigio	pant cool gray 6
04	black / nero	pant black 6

trasparent / trasparenti

39	neutral / neutro	
52	yellow / giallo	pant 116
53	orange / arancio	pant 1505
45	red / rosso	pant 200
59	pink / rosa	pant 1905
41	magenta	pant 213
31	lilac / lilla	pant 2705
51	violet / viola	pant 2425
55	dark violet / viola scuro	pant violet
37	amber / ambra	pant 7571
38	brown / marrone	pant 7582
78	lime	pant 381
49	green / verde	pant 348
47	aquamarine / acquamarina	pant 3272
34	light blue / azzurro	pant 283
67	cyan / ciano	pant 306
44	blue / blu	pant 286
30	light grey / grigio chiaro	pant cool gray 6
40	grey / grigio	pant 437
50	dark grey / grigio scuro	pant 446

solid Icon green and Tag green / Icon green e Tag green coprenti

01	white / bianco	
70	cream / crema	pant 7499
42	yellow / giallo	pant 012
43	orange / arancio	pant 151
35	red / rosso	pant 179
13	brown / marrone	pant 7532
29	green / verde	pant 7741
65	dark green / verde scuro	pant 343
77	cyan / ciano	pant 2995
54	blue / blu	pant 7685
04	black / nero	pant black 6

 RECYCLED PLASTIC PENS / PENNE IN PLASTICA RICICLATA

solid / coprenti

06	ice	
10	cloud	pant cool gray 1 C
76	desert	pant 466 C
87	mud	pant 7532 C
19	forest	pant 7735 C
21	abyss	pant 654 C
58	graphite	pant 425 C
07	onyx	

Pantone colours are available on demand. Please contact us to find out the minimum order quantity for each model.

I colori Pantone sono disponibili su richiesta, contattateci per conoscere i quantitativi minimi per ogni modello.

♻️ RECYCLED PLASTIC PENS / PENNE IN PLASTICA RICICLATA — solid / coprenti

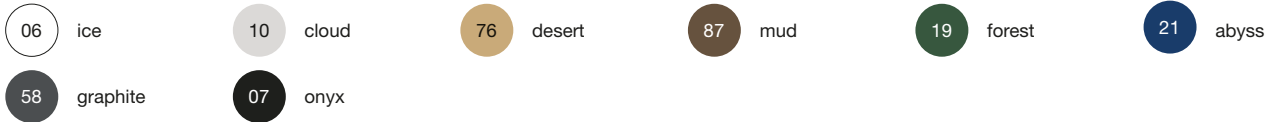

solid / coprenti



transparent / trasparenti

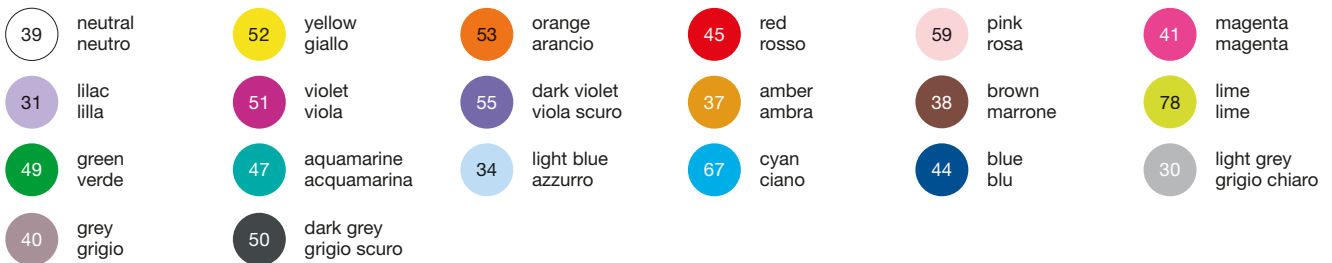

solid Icon green and Tag green / Icon green e Tag green coprenti



metallic paintings / vernici metallizzate

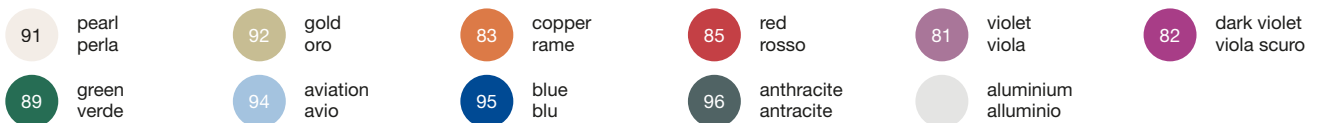

solid fluo / fluo coprenti



transparent fluo / fluo trasparenti



galvanic process / trattamento galvanico



metal finishes / finiture metallo



LESS PENS.

TY-QU

S.



BUY LESS

PENS